

422A/424A Gated Compressor/ Limiter/De-Esser

OPERATING MANUAL

orban

422A/424A Gated Compressor/ Limiter/De-Esser

OPERATING MANUAL

orban

Orban Associates Inc. 645 Bryant St., San Francisco, CA 94107 (415) 957-1067
Telex: 17-1480 Cable: ORBANAUDIO

GAIN REDUCTION:
Reads the gain of the VCA, from 0 to -25dB. Shows the effect of any control but OUTPUT TRIM and DE-ESSER.

INPUT ATTEN.:
Adjusts drive to compressor/limiter, determining amount of G/R.

ATTACK TIME:
Adjusts speed of response to input level increase. Fast: peak limiter & compressor only
Slow: compressor only

GATE THRESH.:
Determines the input level that causes "gating"; VCA gain moves slowly to IDLE GAIN control setting.

OUTPUT TRIM:
Adjusts VCA gain to control or prevent clipping; its effect is seen on VCA LEVEL meter; not an output attenuator (Output Attenuator located on rear).

DE-ESSER OPERATE/DEFEAT:
Activates or defeats de-esser control circuitry.

COUPLED/INDEP:
Couples A and B gain and gating circuits for stereo tracking.

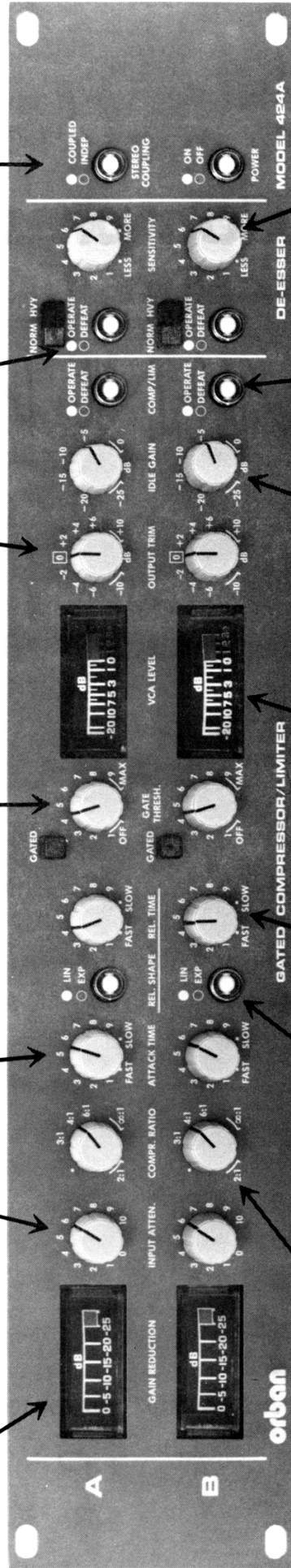

COMPR. RATIO:
Adjusts compression from "looser" (2:1) to "tighter" (∞ :1).

REL. SHAPE: Lin: compressor releases at constant rate
Exp: release starts slower, then speeds up

REL. TIME:
Adjusts speed of gain increase when output level is below threshold of compression.

VCA LEVEL:
Reads peak operating level of VCA. Clipping occurs above approximately "+2".

IDLE GAIN:
Determines VCA gain when unit is gated (OPERATE mode) or anytime unit is DEFEATED.

OPERATE/DEFEAT:
Activates or defeats comp/lim control circuitry. Does not bypass any circuitry.

DE-ESSER SENSITIVITY:
Adjusts threshold of de-essing.

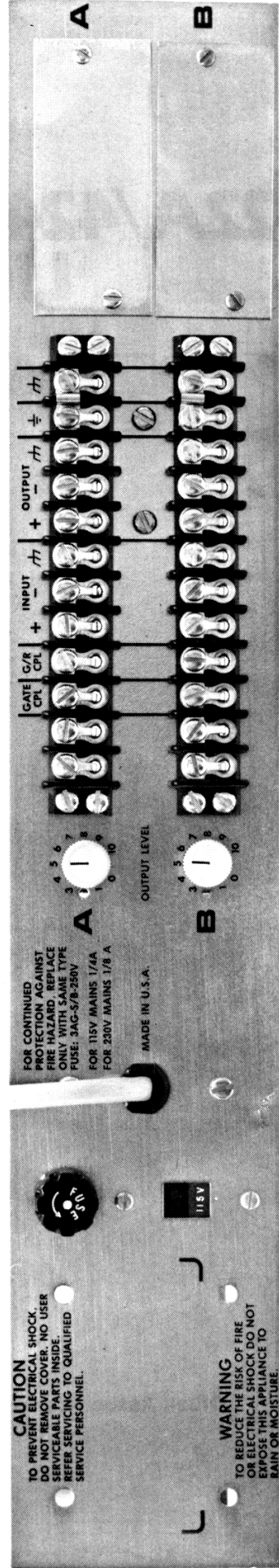

CAUTION
TO PREVENT ELECTRICAL SHOCK, DO NOT REMOVE COVER. NO USER SERVICEABLE PARTS INSIDE. REFER SERVICING TO QUALIFIED SERVICE PERSONNEL.

WARNING
TO REDUCE THE RISK OF FIRE OR ELECTRICAL SHOCK DO NOT EXPOSE THIS APPLIANCE TO RAIN OR MOISTURE.

FOR CONTINUED PROTECTION AGAINST FIRE HAZARD, REPLACE ONLY WITH SAME TYPE FUSE, 3AG-3/8-250V FOR 115V MAINS 1/4A FOR 230V MAINS 1/8 A

MADE IN U.S.A.

Table of Contents

About This Manual	
Registration Card	
Warranty	
I Condensed Operating Instructions	
5 Part A: Introduction	
5 Performance Highlights	
6 Front-Panel Description	
6 Rear-Panel Description	
7 Part B: Installation	
7 Mechanical Installation	
7 Electrical Installation	
AC Power	
Control Loop Bass Rolloff	
Audio	
Output	
Preferred Wiring	
Table I: General Input/Output Connection Rules	
Wiring The 424A With Single-Conductor Shielded Cable	
11 Part C: Operating Instructions	
11 Description and Function of Front-Panel Features	
Using The Compressor/Limiter	
Using The De-Esser	
Adjusting The OUTPUT ATTEN Control	
19 Some Specific Applications	
Adjusting The 424A To Provide Peak Overload Protection	
Stereo And Multichannel Operation	
Speech-Activated Ducking Of Music	
21 Part D: Maintenance	
21 Introduction	
21 ALIGNMENT AND PERFORMANCE VERIFICATION	
General	
Power Supply	
Signal Processing Circuitry	
27 MAINTENANCE AND SERVICE	
Preventive Maintenance	
Corrective Maintenance	
Service Access	
Lamp Replacement	
Component Replacement	
Replacement Parts	
Replacement Of Components On Printed Circuit Boards	
Removal	
Installation	
Troubleshooting IC Opamps	
Factory Service	
Shipping Instructions	
31 CIRCUIT DESCRIPTION	
General	
Input Buffer	
Voltage-Controlled Amplifier (VCA) Operation	
Current-Controlled Gain	
Exponential Converter	
Compressor/Limiter Circuitry	
General	
Rectifier With Threshold	
Timing Module	
Threshold-Setting Circuitry and RATIO Control	
Gating Circuitry	
Gain Reduction Meter	
De-Esser Control Circuitry	
VCA LEVEL Meter	
Power Supply	
40 APPENDIX A: INTERCONNECTIONS AND GROUNDING	
42 APPENDIX B: SPECIFICATIONS	
44 PARTS LIST	
53 SCHEMATIC	
54 PARTS LOCATOR	

ABOUT THIS MANUAL

Except for the first few sections, the information contained in this manual is primarily for reference and to aid maintenance. The unit has been designed to be straightforward and intuitive to use, and most experienced compressor/limiter users will be able to use it easily without instruction.

However, a number of subtle features have been included. Full understanding of these will enable anyone -- beginner or pro -- to get the most of the unit. Time spent with the manual will often yield substantial rewards.

REGISTRATION CARD

The original purchaser should have received a postpaid Registration Card packed with this manual.

Registration is of benefit to you because it enables us to tell you of new applications, possible performance improvements, service aids, etc., which may be developed over the life of the product. It also provides us with the date of sale so that we may more promptly respond to possible claims under Warranty in the future (without having to request a copy of your Bill of Sale or other proof of purchase).

Please fill in the Registration Card and return it to us.

If the Registration Card has become lost or you have purchased the unit used, please photocopy the image of the card reproduced below and send it to us in an envelope. Use the address shown on the title page.

Model # _____	Serial # _____
Name or Title _____	
Organization _____	
Street _____	
City/State/Country _____	
Zip or Mail Code _____	
Purchased from _____	City _____ Date of Purchase _____
Nature of your application _____	
How did you hear about it? _____	
Comments: _____	

Fig. A-1: REGISTRATION CARD

WARRANTY

The Warranty, which applies only to the first end-user of record, is stated on the Warranty Certificate on a separate sheet packed with this manual. Save it for future reference.

Details on obtaining factory service are provided in **Part D**.

Condensed Operating Instructions

These instructions are primarily designed to help you get started using your 422A/424A. (The later parts of your **OPERATING MANUAL** contain much more detail, and will help you get the most from your 422A/424A after you have become familiar with the basics.)

Operationally, the 422A/424A can be considered to be a basic compressor/limiter with enhancements. If you are just beginning to learn about it, or if you only need basic compressor functions, you needn't worry about these enhancements.

Most of the enhancements are associated with the Gating function. If the GATE THRESHold control is turned OFF (fully counterclockwise), these enhancements are not operative and need not concern you now.

To Use The Compressor/Limiter: Preset the following controls:

REL SHAPE	LIN
GATE THRESH	OFF
OUTPUT TRIM	0 (at the detent)
IDLE GAIN	0
COMP/LIMITER OPERATE/DEFEAT	OPERATE
DE-ESSER OPERATE/DEFEAT	DEFEAT

You then need to deal with only four familiar controls: INPUT ATTENUator, RATIO, ATTACK TIME, and RELEASE TIME. These controls are always adjusted by ear to obtain the desired sound. If you have used any common professional compressor or limiter before, these controls should operate intuitively:

- 1) Adjust the INPUT ATTENUator control until the GAIN REDUCTION (G/R) meter indicates the desired amount of G/R. Don't let the G/R meter enter the red section of the scale.
- 2) Adjust the RATIO control to determine if compression will be "tight" or "loose". "Tight" means that a large increase in input level will produce a small increase in output level. As the ratio becomes "looser", the output level will change more and more for a given change in input level. 2:1 is the "loosest" ratio; infinity:1 is the "tightest". "Looser" ratios tend to give more natural, dynamic sound at the expense of lower loudness and less consistent levels.

(Adjusting the RATIO control to "looser" settings automatically lowers the compression threshold to prevent peak overload of the 422A/424A circuitry or of the device being driven by the 422A/424A when high amounts of gain reduction are used.)

- 3) Adjust the ATTACK TIME control to determine how quickly the 422A/424A responds to an input level increase. Fast attack times produce the most consistent control of peak levels (and therefore produce highest loudness). However, their effect tends to be more audible than that of slow attack times. Slow attack times permit transient material to pass through the 422A/424A unaffected, so that transient definition is retained.

(To prevent transient overshoots permitted by slow attack times from overloading either the 422A/424A circuitry or devices being driven by the 422A/424A, the threshold of compression is reduced as the attack time is made slower. This way, the peak level at the output remains approximately constant as the ATTACK TIME control is adjusted.)

The ATTACK TIME control is calibrated with an arbitrary scale because the attack time is automatically varied according to the nature of the program material. This minimizes audible compression-induced side-effects.

Because the range of the ATTACK TIME control has purposely been made very wide, certain sounds can cause the 422A/424A to produce distortion when operated with fast attack times. Such sounds include certain male voices, Hammond organ, and some types of bass (particularly synthesizer-produced). Such distortion can be totally eliminated by operating with slower attack times -- usually between "5" and "SLOW" on the dial.

- 4) Adjust the RELEASE TIME control to determine how fast the 422A/424A gain recovers toward maximum during those times when its output level is below the threshold of compression.

Fast release times produce the greatest "density" and most consistent output levels. However, they also create the greatest risk of audible side-effects. They are most useful in recording studios or production situations where the program material being processed is a single track and is to be mixed with other material.

Slower release times generally produce a more natural sound on mixed program material. Accordingly, they are more useful in such applications as broadcast production or cassette duplication.

The RELEASE TIME control is calibrated with an arbitrary scale because the release time is automatically varied according to the nature of the program material. This minimizes audible compression-induced side-effects.

(The RELease SHAPE switch determines if the release proceeds at a constant number of dB per second (LINEar), or if it starts more slowly and then speeds up as it progresses (EXPOntial). LINEar usually sounds most natural, but EXPOntial can be useful if you want to create the "open" sound associated with slow release times, yet gain-ride quickly during pauses or low-level program material. Like the other controls, it should be adjusted "by ear" to your taste.)

- 5) It is important to note that the OUTPUT TRIM control should not be treated like a familiar "output attenuator" control: It is ordinarily left at "0". Its purpose is to permit you to operate the Voltage-Controlled Amplifier (VCA) in the optimum part of its range for your application. You can use the OUTPUT TRIM control to create controlled clipping in the VCA, to prevent VCA clipping, or to optimize the signal-to-noise ratio. Refer to the **OPERATING MANUAL** for further details.)

A standard OUTPUT ATTENUator control is located on the rear panel.

Compressor/Limiter Enhancements: The IDLE GAIN control determines the gain of the Compressor/Limiter when the COMP/LIM OPERATE/DEFEAT switch is in DEFEAT. If the IDLE GAIN control is set close to the average amount of gain reduction, the Compressor/Limiter can be defeated and reactivated in the middle of program material without obvious side-effects such as sudden gain changes. (The control also has a second function which will be explained below.)

The gating features permit the 422A/424A to handle noise or low-level program material differently than it handles high-level program material. The gating feature is not the same as a conventional "noise gate": It is not intended to reduce noise or other undesired sounds below the level at which they exist in the original program. Its purpose is to prevent compression from unnaturally exaggerating such material. If needed, a conventional noise gate can be used before the 422A/424A.

The gating feature is activated whenever the GATED lamp is on. This lamp will turn on whenever the input level drops below a threshold set with the GATE THRESHOLD control. (In its OFF position, this control totally defeats the gating feature.)

When the GATED lamp is on, the gain of the Compressor/Limiter moves slowly to a point set by the IDLE GAIN control. This gain change is indicated on the GAIN REDUCTION meter. If the IDLE GAIN control is set at a point equal to the average amount of gain reduction occurring, then gain will neither increase nor decrease during low-level program material or pauses. In particular, noise will not be "pumped up" as in a conventional compressor. For example, if you are compressing a particular track in a multitrack mixdown, tape hiss or low-level material below the gating threshold will not be increased in level at the beginning of the mix (before high-level program material first appears on the track), or during pauses in the track.

If the IDLE GAIN control is set lower than the average gain reduction, then it can leave a "hole" when high-level program material reappears and turns the GATED lamp off. This is because the Compressor/Limiter must recover to a higher gain to produce full loudness, and this cannot happen instantaneously: The time necessary for recovery is determined by the RELEASE TIME control.

To Use The De-esser: To use the De-esser, switch the DE-ESSER OPERATE/DEFEAT switch to OPERATE and adjust the De-esser SENSITIVITY control until "esses" sound naturally balanced with the rest of the voice.

The threshold of de-essing is fixed by the SENSITIVITY control, and does not track the average vocal level (as in the Orban dedicated de-essers). For consistent de-essing, it is important that the level presented to the De-esser be relatively constant. This is ordinarily achieved by compressing the voice with the Compressor/Limiter, which is functionally ahead of the De-esser.

It is sometimes possible to de-ess vocals which have been mixed with other material. Each case must be evaluated by ear. The DE-ESSER OPERATE/DEFEAT switch does not introduce clicks, pops, or discontinuities into the program, so the De-esser can be keyed in or out in the middle of program material as required. This may be the best way to handle a few problem "esses" in mixed program material.

Part A: Introduction

The Orban Model 422A/424A Compressor/Limiter/De-Esser is an integrated AGC device of highest professional quality. It can perform compression, peak limiting, and vocal de-essing functions simultaneously with unusual freedom from side-effects. It can thus serve either as a general-purpose no-compromise compressor/limiter, or as a complete dynamic processor for conditioning vocals. However, it is not optimized for overmodulation protection of broadcast transmitters, and the Orban OPTIMOD-AM, -FM, or -TV should be used in such applications.

The flexibility and natural sound of the 422A/424A make it applicable in other areas of professional audio as well: recording studios, sound reinforcement, public address, motion picture sound, etc.

The product is available in both single- (422A) and dual- (424A) channel versions. (For clarity, only the 424A will be referenced in this manual.) The dual-channel version is equipped with a coupling switch which forces the gain of both channels to be equal, tracking the channel demanding the greatest amount of gain reduction. This preserves correct imaging in stereo applications. However, the stereo coupling switch does not couple the operating controls, and these are ordinarily set identically in stereo operation.

Attack and release times are both program-controlled, but can be scaled faster or slower by means of front-panel controls. This results in maximum flexibility, plus extremely natural sound over a wide range of control settings.

The 424A Compressor is equipped with electronically-balanced input and output, and is compatible with the levels and impedances found in both professional and semi-professional applications. RF suppression applied to the input, output, and power leads enables use in relatively high EMI fields such as those common in broadcasting.

The controls and features of the 424A Compressor are fully described in this manual. It will familiarize you with the unit's potential and enable you to imaginatively use the 424A for your specific installation and application.

Because the front-panel controls are marked in a familiar way, you may be tempted to jump right in without reading the manual. However, if you take the time to review the **Description And Function Of Front-Panel Controls** and **Operating Instructions** in **Part C**, you will find that there is "more than meets the eye" inside the 424A, and that the time you take reading the manual will be well-rewarded by a greater understanding of the unit's potential.

PERFORMANCE HIGHLIGHTS

- Production AGC function using circuitry adapted from industry-standard OPTIMOD-FM Model 8100A broadcast signal processor
- De-esser characteristics similar to highly-accepted Orban dedicated de-essers
- Independent compressor/limiter and de-esser control loops with optimized, program-controlled parameters for each
- Unbeatable ability to increase average loudness of program material or individual tracks without introducing unnatural sound quality or artifacts
- Defeatable gain-freezing gate with user-adjustable threshold to prevent pumping and breathing during pauses

- Wide-range attack time, release time, and ratio controls permit device to sound extremely natural or to create special effects
- Extremely easy to use because attack and release time controls interact and also change the compression threshold, assuring consistent peak output levels and minimizing need for manual readjustment of the output attenuator
- Operation is intuitive and natural -- you don't need a chart or an advanced degree to figure out what's happening
- Low-distortion operation teams clean class-A VCA with all-important dynamic distortion reduction in the control circuitry
- 25dB gain reduction range with constant 90dB (typical) clip-to-noise ratio regardless of amount of gain reduction
- Better than 25dB de-ess gain reduction available in addition to the 25dB compressor/limiter gain reduction
- True peak-reading output level meter allows operator to positively prevent VCA clipping -- or to use a controlled amount of clipping to limit peak levels
- True peak-reading gain reduction meter
- Choice of general-purpose linear or special-purpose exponential release characteristics
- Strong all-metal 19" rack mount package for ruggedness, roadworthiness, RFI shielding, and ease of mounting
- Lighted meters with long-life lamps
- Input, output, and AC power RFI suppression make the unit ideal for difficult environments like broadcast stations, areas near mobile communications transmitters, etc.
- Balanced inputs and outputs
- 115/230V 50/60Hz power supply standard
- Industrial-grade parts and construction
- Highly cost-effective

FRONT PANEL DESCRIPTION

The Front-Panel Photograph at the beginning of this Manual shows the various operating controls. These controls and their operation are fully described in **Description and Function of Front Panel Features** in **Part C (Operating Instructions)** below.

REAR PANEL DESCRIPTION

The FUSE used in both the 422A and the 424A is a 1/4A (115 volt operation) or 1/8A (230 volt operation) 3AG 250V SLO-BLO type. Replace with the same type only.

The OUTPUT ATTENUATOR is fully described in **Description and Function of Front Panel Features** in **Part C (Operating Instructions)** below.

The INPUT and OUTPUT connectors provided allow connection via barrier strip (#5 screw). Holes are provided for installation of "XLR"-type connectors, and a retrofit kit is available from your dealer.

Please refer to the **Electrical Installation** section for connection instructions.

Part B: Installation

MECHANICAL INSTALLATION

Vertical space of two standard rack units (3 1/2"/8.9cm) is required for either the 422A or the 424A.

Mounting the unit directly over large heat-producing devices like a vacuum-tube power amplifier may shorten component life and is not recommended. Ambient temperature should not exceed 113 degrees F (45 degrees C) when equipment is powered.

ELECTRICAL INSTALLATION

AC Power

The power transformer can be connected for 115 volt or 230 volt 50 or 60Hz AC operation by means of a selector switch on the rear panel.

The power cord is terminated in a "U-Ground" plug to USA standards. The green (or green/yellow) wire (which is connected to the long prong) is connected directly to the 424A chassis. If it becomes necessary to lift this ground to suppress ground loops, this should be done with a three-prong to two-prong adapter plug, rather than by damaging the power plug. It is not recommended that this ground be defeated unless absolutely necessary because it eliminates the intrinsic safety feature of the three-wire system.

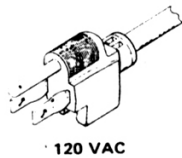

Power Cord Conductor Identification		
Conductor	Color	Alternate Color
Ungrounded (Line)	Brown	Black
Grounded (Neutral)	Blue	White
Grounding (Earthing)	Green-Yellow	Green

Fig. B-1: AC LINE CORD COLOR CODING

WARNING!

IF THE GROUND IS DEFEATED, CERTAIN FAULT CONDITIONS IN THE UNIT OR THE SYSTEM TO WHICH IT IS CONNECTED CAN RESULT IN APPEARANCE OF FULL LINE VOLTAGE BETWEEN CHASSIS AND EARTH GROUND. SUCH VOLTAGE IS CAPABLE OF CAUSING ELECTRICAL SHOCK, POSSIBLY RESULTING IN SEVERE INJURY OR DEATH!

Control Loop Bass Rolloff

The compressor/limiter control loop is ordinarily operated with a bass rolloff which simulates the response of the ear and results in a more natural sound. However, certain applications demand that the 424A perform an accurate peak limiting function. This requires a "flat" response from the control loop.

The bass rolloff network can be jumpered out on the circuit board(s) inside the 424A. Each unit is shipped with the jumpers in the "rolloff" position. To restrap to the "flat" position, move the jumpers according to Fig. B-2, following the **User Access** instructions in **Part D**.

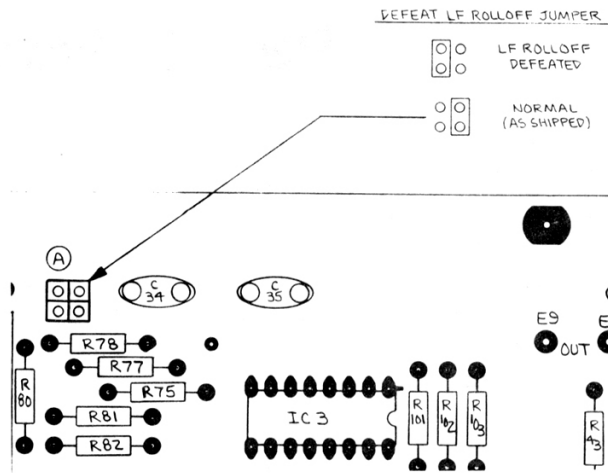

Fig. B-2: Control Loop Bass Rolloff Strapping

Audio

Connecting the 424A Compressor to other equipment is quite straightforward. Relatively uncomplicated systems (such as home playback systems, "semi-pro" recording studios, electronic music studios, dance bars, etc.) tend to come together without serious grounding problems even if the wiring practices are somewhat casual, provided that high RF fields are not present. Unusual situations can be analyzed if you are familiar with the standard rules governing grounding and interfacing between balanced and unbalanced systems.

The instructions below will apply to the majority of cases. A comprehensive discussion of interconnections and grounding can be found in **Appendix A**.

Input: The electronically-balanced input of each channel of the 424A Compressor is compatible with most professional and semi-professional sound equipment, balanced or unbalanced, whose source impedance is 600 ohms or less. If it is greater (as in some vacuum-tube audiophile preamps), a minor modification may be made to the input to accommodate the situation. Please refer to **Appendix A** for further details.

Nominal input level is between -10 and +4dBm. The absolute overload point is +20dBm.

Output: The two outputs of each channel of the 424A are electronically-balanced to ground. The source impedance of each leg is 47 ohms in parallel with 1000pF to the chassis (for RFI suppression). Each output is capable of driving loads of 600 ohms or higher.

If an unbalanced output is required (to drive unbalanced inputs of other equipment), it should be taken between the (+) output and circuit ground. **DO NOT GROUND THE (-) OUTPUT.** While no immediate damage will result, this will short the output of the (-) amplifier to ground through a 47 ohm resistor, significantly stressing the output amplifier IC and possibly shortening its life due to thermal cycling.

Preferred Wiring: We recommend wiring with two-conductor shielded cable (such as Belden 8451 or equivalent) because signal current flows through the two conductors only. The shield does not carry signal, is used only for shielding, and is ordinarily connected to ground at one end only. The following table and diagram are applicable to a great majority of installations.

If you wish to use single-conductor shielded cable, see the section immediately below.

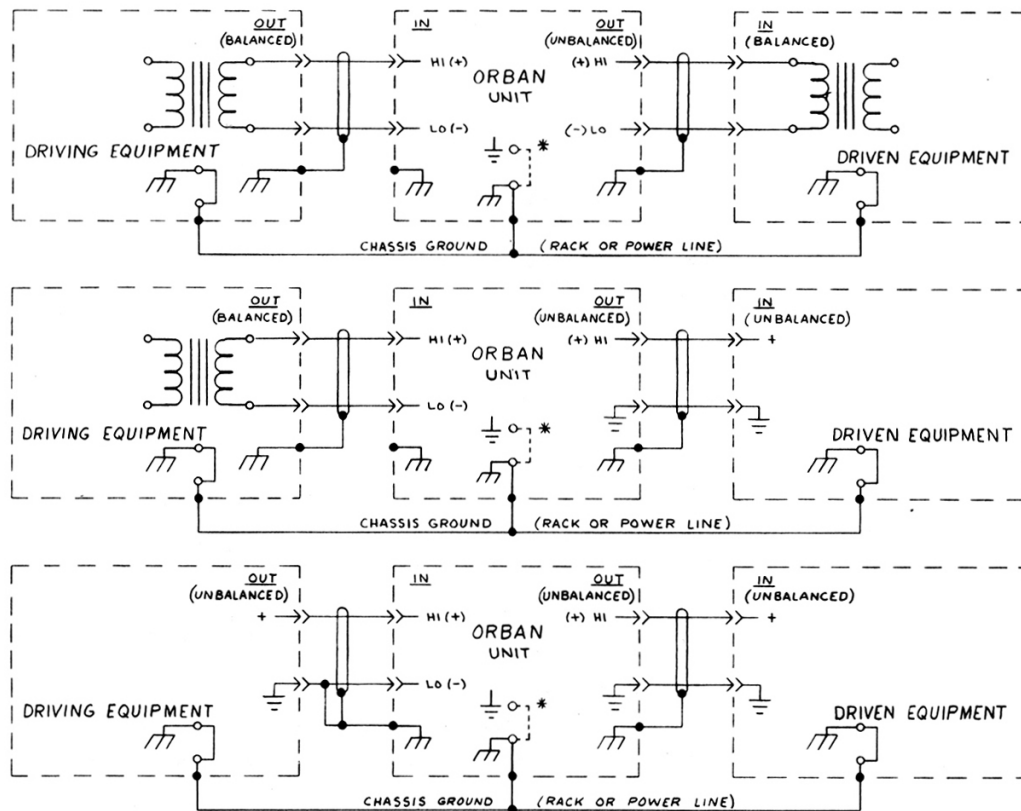

Fig. B-3: GROUNDING

TABLE I:
GENERAL INPUT/OUTPUT CONNECTION RULES

INPUT

- 1) Always use "+" and "-" as the two input terminals to the 424A.
- 2) When the 424A is driven from an unbalanced source, connect shield both to circuit ground of source, and to chassis ground of 424A.
- 3) When the 424A is driven from a balanced source, connect shield at source end to chassis ground. Do not connect shield at 424A end.

OUTPUT

- 1) On the 424A output, connect shield at 424A end to chassis ground (whether driving balanced or unbalanced). Do not connect shield at other end.
- 2) When driving a balanced load, jumper circuit ground to chassis ground on 424A (on rear panel). When driving an unbalanced load, do not attach jumper.
- 3) When driving an unbalanced load, connect the the input ground of the driven equipment to the 424A's circuit ground (not to the 424A's (-) output). Connect the hot side of the driven equipment's input to the 424A's (+) output.

GENERAL

- 1) 424A chassis should always be earth-grounded (i.e. through third wire in power cord or through rack.) for maximum protection from shock. Float this ground only as last resort.

Because it is not always possible to determine if the equipment driving or being driven by the 424A has its circuit ground internally connected to its chassis ground (which is always connected to the ground prong of the AC line cord, if present), and because the use of the AC power line ground often introduces noise or other imperfections such as RFI, hum, clicks, and buzzes, the wiring techniques in the diagram are not universally applicable.

If you follow the diagram and hum or noise appears, don't be afraid to experiment. If the noise sounds like a low-level crackling buzz, then probably there isn't enough grounding. Try connecting the "-" input of the 424A to a chassis ground terminal on the barrier strip and see if the buzz goes away. You can also try strapping the 424A's chassis and circuit grounds together, and see if this helps.

A ground loop usually causes a smooth, steady hum rather than a crackly buzz. If you have a ground loop, you can often break it by disconnecting the jumper between circuit and chassis grounds on the 424A's rear-panel barrier strip. In either case, think carefully about what is going on, and keep in mind the general principle: one and only one circuit ground path should exist between each piece of equipment! (Bear in mind that the circuit grounds of the two channels of the 424A dual-channel unit are connected together internally, and could conceivably introduce a ground loop if you do not take this connection into account in planning your wiring.)

Wiring The 424A With Single-Conductor Shielded Cable: Sometimes, particularly if you are using the 424A with musical instruments or home-type equipment, single-conductor shielded cable may be the only type immediately available, making it impractical to use the preferred two-conductor cable. In this case, connect the inner conductors of the shielded cables to the "+" sides of the 424A inputs and outputs. Connect the shield of the 424A input cable to the "-" input, and connect the shield of the 424A output cable to the 424A circuit ground terminal on the rear-panel barrier strip.

The shield will ordinarily receive chassis ground from the external equipment which it is connecting to the output of the 424A. The chassis ground/circuit ground jumper on the rear barrier strip of the 424A should be left in whichever configuration gives minimum hum or buzz. To minimize hum or buzz, it may be necessary to jumper one or more shields to chassis ground. Because use of single-conductor cables virtually eliminates any possibility of carefully controlling the system grounding scheme, it is NOT RECOMMENDED! Even so, it often does work adequately.

Part C: Operating Instructions

FRONT PANEL DESCRIPTION AND FUNCTION

While the following control descriptions might seem unnecessarily complex on first reading, they have been crafted to answer any reasonable question either the beginner or the experienced user might ask. The effects of, and interactions between, the controls have been designed to promote ease of use, facilitating good results with minimum effort. Some of these interactions and effects are subtle, and are much more easily appreciated by actual practice than by reading.

Refer to the Front-Panel Photograph at the beginning of this Manual.

- The GAIN REDUCTION meter is electronically conditioned to show the true peak gain reduction of the compressor/limiter section, in dB. It does not indicate the amount of de-essing gain reduction, which is indicated by illumination of the NORMAL and HEAVY de-essing indicators.

If the meter enters the red part of the scale, it indicates that no further gain reduction is available in the compressor/limiter section, and that audible "gulping" or other peculiarities caused by the control loop's saturating are imminent.

- The INPUT ATTENUATOR adjusts the drive level to the compressor/limiter, thus determining the amount of gain reduction. (NOTE: There is no user-adjustable THRESHOLD control. However, adjusting either the ATTACK TIME or RATIO controls also adjusts the threshold to keep the peak output level approximately constant.)
- The COMPRESSION RATIO control adjusts the compression ratio (i.e., the dB change in input level divided by the resultant dB change in output level). The calibrations are only valid at the threshold of gain reduction. As more gain reduction is used, the compression ratio increases, yielding a "soft knee" curve when the COMPRESSION RATIO control is adjusted for lower ratios.

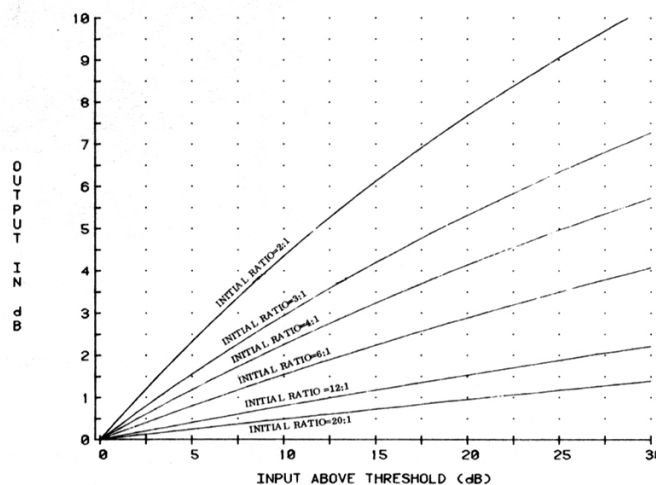

Fig. C-1: OUTPUT LEVEL AS A FUNCTION OF INPUT LEVEL FOR VARIOUS SETTINGS OF THE RATIO CONTROL

- The ATTACK TIME control scales the program-controlled attack characteristic faster or slower, and simultaneously adjusts the compression threshold. (The attack time is not constant.)

At faster ATTACK TIME settings, substantial peak limiting action is produced with typical program material. As the ATTACK TIME is slowed, the 424A acts more and more like a pure compressor, and fast peaks are permitted to overshoot more and more.

Because overshoots tend to increase, the compression threshold is automatically lowered as the attack time is slowed to avoid clipping the Voltage-Controlled Amplifier (VCA) used as the gain-control element. At the very slowest attack times, the release time is also lengthened by a factor of approximately 4:1 to assure that the 424A is working in a truly "averaging" mode at these very slow attack times, and that the attack time does not get slower than the release time.

- The RELEASE TIME control scales the program-controlled release characteristic faster and slower. (The release time is not constant; it is varied according to the previous history of the program dynamics.)

To avoid having fast transients punch "holes" in the program material, the release rate is automatically speeded up after a large change in gain reduction. This creates a fast "peak limiting" function which rides on top of a much slower "compression" function. It is the recovery rate of the "compression" function which is affected by the RELEASE TIME control.

- The RELEASE SHAPE switch further modifies the action of the RELEASE TIME control. It determines if the recovery rate (in dB/second) of the "compression" function is constant (LINear mode), or if it starts out slowly, and then speeds up as it goes along (EXponential mode), as in Fig. C-2. (The fast limiting recovery is unaffected by the RELEASE SHAPE switch.)

The LINear mode almost always sounds more natural.

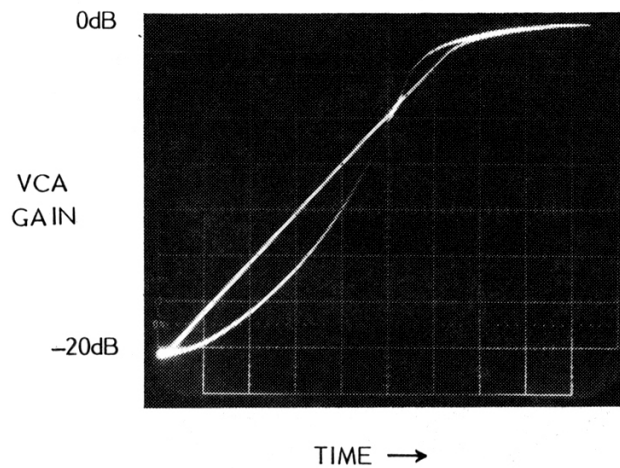

Fig. C-2: LINear VERSUS EXponential RELEASE SHAPES

While the initial release rate (dB/sec) in EXponential mode is approximately three times slower than in LINear mode for a given setting of the RELEASE TIME control, with large amounts of gain reduction it becomes approximately three times faster than LINear mode by the time the compressor has fully recovered.

The EXponential mode is useful when the 424A is used to ride gain on wide dynamic-range program material (such as certain vocalists), yet a very "open" sound (associated with slow release times) is desired.

- The GATE THRESHold control determines the input level at which the compressor release process becomes "gated". When this happens, the compressor gain "freezes" wherever it happens to be, then immediately starts slowly drifting to a point pre-determined by the setting of the IDLE GAIN control (see below).

The fast limiting release process is unaffected.

Under this condition, the GATE lamp is lit.

The gating function can be used to prevent noise "pump-up" or "breathing" during pauses and/or to control hiss from empty tracks at the beginning of a mix. A conventional non-gated compressor would recover to full gain, increasing noise levels.

This function is not the same as the familiar "noise gate" or "expansion" function. If further noise reduction is desired, a conventional full-featured noise gate can be used ahead of the 424A. However, if the 424A's IDLE GAIN control is set to match the average amount of gain reduction, more subtle processing than that produced by a noise gate is achieved since noise will neither increase nor decrease during pauses.

The gating function is defeatable by turning the GATE THRESHold control fully counterclockwise. In a sense, the gating function is the opposite of the EXponential release function, in that the gating function slows and redirects the release characteristic during pauses, while the EXponential function speeds up the release process. However, the gating function can still be operated when in the EXponential release time mode, and it is possible that the two functions may complement each other in certain applications. Only experimentation can tell!

- The VCA LEVEL meter indicates the peak output level of the 424A compressor/limiter voltage-controlled amplifier (VCA). Ordinarily, it will unambiguously indicate VCA clipping, which occurs at approximately "+3dB" on the meter.

The meter accurately captures and holds the peak level of even the fastest program peaks, and will read within 0.5dB of the true peak value of a 10 microsecond pulse.

However, it is possible that VCA clipping will not be identified if high-energy, high-frequency program material is processed by both the compressor/limiter and de-esser sections simultaneously. In this case, clipping may occur in the compressor/limiter section of the VCA, yet the de-esser section of the VCA may reduce the final VCA output level as observed on the VCA LEVEL meter such that clipping is not indicated. (Ordinarily, a moderate amount of clipping of program material of this type is not audibly offensive.)

- The OUTPUT TRIM control is a gain control used to control or to prevent clipping in the VCA. IT IS NOT A CONVENTIONAL OUTPUT ATTENUATOR CONTROL, AND MUST NOT BE USED AS SUCH, LEST THE VCA BE OPERATED IN A NON-OPTIMUM PART OF ITS GAIN CONTROL RANGE!

The performance of the VCA used in the 424A is optimized with regard to noise and distortion over a 25dB gain reduction range. When the OUTPUT TRIM control is on the "0" detent, it guarantees that the VCA will be operated in the optimum part of its range regardless of the amount of gain reduction as indicated on the GAIN REDUCTION meter.

Turning down the OUTPUT TRIM control simultaneously lowers the VCA gain and the compression threshold so that the gain reduction remains approximately constant. At the same time, the amount of available gain reduction is reduced. For example, if the OUTPUT TRIM control is set to "-5dB", then the maximum available gain reduction is 20dB, instead of 25dB.

Certain very "spiky" program material will tend to overshoot more than average program material, thus partially foiling the automatic adjustment of compression threshold as ATTACK and/or RATIO controls are operated (as described above). These excessive overshoots (which are clearly indicated on the true peak-reading VCA LEVEL meter) can clip the VCA unless the OUTPUT TRIM control is turned down.

If you wish to obtain a more natural sound than that produced by very fast attack times in applications where the absolute peak levels are important (such as overmodulation protection of a broadcast studio-transmitter link or disk cutter protection), this improved naturalness can often be achieved by operating with slower attack times and clipping off the higher-amplitude overshoots in the VCA. This can be done by advancing the OUTPUT TRIM control until the desired amount of clipping is observed.

You will find that turning the control up usually does not result in output level increases proportional to those calibrated on the dial, and also results in increased gain reduction. This is because the 424A contains circuitry which automatically speeds up the attack time and reduces overshoots as the VCA approaches its clipping point, thus "fighting" any tendency towards clipping by automatically increasing the gain reduction if clipping is imminent.

To reiterate: IF THE OUTPUT TRIM CONTROL IS NOT NEEDED TO EITHER PREVENT OR CREATE CLIPPING, IT SHOULD BE LEFT ON "0".

- The OUTPUT ATTENUator control is located on the rear panel. It adjusts the gain of the balanced line amplifier in the 424A, and is used to match the output level of the 424A to subsequent equipment which lacks a convenient input sensitivity adjustment.

The peak output level required from the 424A is ordinarily determined by the overload point of the driven equipment (amplifier clipping, tape saturation, etc.). In almost all cases, the 424A OUTPUT ATTENUator therefore need be adjusted only once in a given system.

The effect of adjusting the OUTPUT ATTENUator is not indicated on the VCA LEVEL meter as the OUTPUT ATTENUator control is located after all compressor/limiter and de-esser circuitry.

- The IDLE GAIN control is a bit tricky.

It enables the user to preset the "idle" gain of the compressor/limiter at some level between no gain reduction and full gain reduction when either:

- a) A low-level passage or pause occurs in the program, activating the gating feature and causing the GATE lamp to come on, or

- b) The compressor/limiter is manually defeated by means of the COMPRESSOR OPERate/DEFEAT switch.

This feature, in either mode, enables the operator to avoid sudden, unpredictable gain changes under typical "real-world" conditions. In mode (a), the gain is prevented from freezing permanently at an abnormally low or high value during low-level program or pauses which have automatically activated the gate. (The gate is activated when the input level drops below a level adjusted by the operator means of the GATE THRESHold control.) Instead of freezing permanently, the gain drifts very slowly, up or down, toward the point set by the operator by means of the IDLE GAIN control.

The IDLE GAIN control is ordinarily set to match the average amount of gain reduction used. If the gain were too high when the program restarted, then hiss or noise would be unnecessarily increased. If the gain were too low, a "hole" would occur until the compressor had a chance to recover through the normal release process.

Thus the IDLE GAIN control permits the compressor to unobtrusively bridge through low-level program and silence, neither pumping up noise during pauses nor introducing "holes" once the program restarts. Unlike a conventional noise gate, it does not cut off ambience and/or instrument decays and is thus more subtle, particularly on mixed program material.

If the gating feature is not activated, then the compressor/limiter will recover to full gain during pauses or low-level passages, and the IDLE GAIN control is ineffective. This mode tends to pump up noise such as tape hiss at the beginning of a mix, and use of the gating and IDLE GAIN features can avoid this and other similar problems.

Similarly, when the compressor/limiter function is manually defeated (mode (b)), the compressor/limiter gain moves fairly quickly (but not abruptly) to the value preset by means of the IDLE GAIN control. If the gain of the compressor/limiter was already at this value (or close to it), then the fact that the compressor/limiter was defeated will be not be detected. Under any circumstances, the switching will be smoother than that resulting from a conventional abrupt in/out switch.

- The compressor/limiter OPERate/DEFEAT switch defeats the gain reduction action of the compressor/limiter section only. (The de-esser is unaffected). In DEFEATED mode, the switch smoothly forces the VCA gain to a constant value fixed by the setting of the IDLE GAIN control.

This switch is NOT a hard-wired bypass switch; if a bypass is necessary to keep a sound system functioning in an emergency mode despite a failure in the 424A, this function must be provided externally.

- The de-esser SENSITIVITY control determines the threshold of de-essing. As it is rotated clockwise, "ess" sounds will be suppressed more and more.

Unlike similar controls on the other Orban de-essers, the 424A SENSITIVITY control adjusts the threshold relative to an absolute level, rather than relative to the average level of the input program material. This means that the 424A de-esser works most consistently only when the vocal has been gain-ridden by the preceding compressor/limiter. A significant advantage of this arrangement is that de-essing of vocals in mixed tracks is far more practical, since the de-esser is less likely to affect low-level high frequency musical material unrelated to the vocal.

- The de-esser OPERate/DEFEAT SWITCH defeats the de-essing action. Because it defeats the control loop only, it causes no clicks, pops, or gain changes when operated, and can be freely operated in the middle of program material. For example, if there are a few problem "esses" in mixed material, the de-esser can be switched-in momentarily as needed, eliminating the danger of unwanted effects on other program material.
- The NORMal and HEAVY de-esser gain reduction lamps indicate, respectively, when normal and potentially excessive de-essing action is occurring.
- The COUPLED/INDEPENDENT switch (424A only) permits the use of the two-channel unit either as two independent compressor/limiter/de-essers, or as a coupled stereo unit. In the COUPLED mode, the gain reduction in both channels tracks that channel calling for the most gain reduction at any given instant. Therefore, stereo imaging is always preserved even if operating controls are adjusted differently on the two channels. (Ordinarily, they would be adjusted to be as identical as possible.)

Even in COUPLED mode, the de-essers remain independent. This is because it has been found that their short release times result in no stereo imaging problems despite their independent operation.

- The POWER ON/OFF switch is self-explanatory.

Using The Compressor/Limiter

To use the Compressor/Limiter section of the 424A, switch the compressor/limiter OPERate/DEFEAT switch to OP.

Adjust the ATTACK TIME, RELEASE TIME, RELEASE SHAPE, and RATIO controls to achieve the sound desired. (An explanation of the operating controls is found above in **Description and Function of Front-Panel Features.**)

Adjust the INPUT ATTENUator control until the desired amount of gain reduction is indicated on the G/R METER. Be careful not to over-compress such that the G/R METER enters the red section of the scale. You may wish to readjust the ATTACK, RELEASE, and RATIO controls to "fine-tune" the sound to your taste. This will often result in a change in the amount of gain reduction, and you may wish to readjust the INPUT ATTENUator to compensate.

If you hear a "hashy" distortion on voice, or on instruments like electric bass, synthesizer, or Hammond organ, this can be completely eliminated by slowing down the attack time. (The "hash" is caused by the very fast release-time peak limiting function modulating the instrument waveforms. By slowing the attack time, you produce less peak limiting, forcing the 424A to behave more like a pure compressor.)

If you hear unnatural "pumping" or "breathing", this can be eliminated by slowing the release time and/or by using the gating functions.

In general, the peak level at the 424A output is relatively constant regardless of the adjustment of the ATTACK and RELEASE TIME controls. If you choose a relatively low RATIO, the peak level will decrease at gain reductions less than 25dB. This prevents VCA clipping if the input level rises sufficiently to cause a full 25dB of gain reduction, since the output level will, in this case, increase significantly due to the low compression ratio.

Because peak output levels are held relatively constant, you can readily hear the effect of adjusting any control upon the relative loudness achieved by the processing. Fast attack and release times and high ratios result in maximum loudness (i.e., low peak-to-average ratios), but introduce the greatest risk of audible side-effects. In the 424A, special circuitry minimizes these effects when compared to conventional limiters and compressors.

If the VCA LEVEL meter reads in the red, there is danger of clipping the compressor/limiter's voltage-controlled amplifier (VCA), and the OUTPUT TRIM control should be turned down. If the VCA LEVEL meter reads substantially below 0dB (which may occur if low compression ratios are being used with small amounts of gain reduction), you may turn the OUTPUT TRIM control up if you wish to improve the signal-to-noise ratio achievable from the 424A itself. (Usually, noise from the program material will dominate noise generated within the 424A, and this exercise may be academic.)

The OUTPUT TRIM control can also be turned up if you wish to purposely clip the VCA to control low-energy overshoots by clipping instead of by gain reduction. This permits the use of slower attack times, and may result in a more natural sound.

If you want the gain to recover to maximum during pauses, turn the GATE THRESH control fully counterclockwise (OFF). If you wish the VCA to settle to a certain user-specified gain during pauses, adjust the GATE THRESH control to determine the level at which this gating occurs, and adjust the IDLE GAIN control to the gain desired. (Compression is most unobtrusive if this control is adjusted to correspond to the average gain reduction being used.)

Using The De-Esser

The de-esser is functionally located after the compressor/limiter, and is essentially independent of it. The compressor/limiter is ordinarily used to control input levels to the de-esser, assuring a constant amount of de-essing. This is because the de-esser attempts to reduce all sibilance ("ess" sounds) to a level fixed by the de-esser THRESHOLD control, instead of to a level which is some fraction of the average input level (as the Orban dedicated de-essers do). The de-esser in the 424A therefore does not track its input level, which must be reasonably constant to assure consistent balance between sibilance and other (voiced) vocal sounds.

To use the de-esser, switch the DE-ESSER OPERate/DEFEAT switch to OP. After you have adjusted the controls in the compressor/limiter section for the desired effect, adjust the de-esser THRESHOLD control until sibilance levels sound natural and properly balanced.

The NORMAl light will flash whenever de-essing is occurring. If the HEAVY light flashes, it almost certainly indicates that you have advanced the de-esser THRESHOLD control too far clockwise, and that excessive de-esser gain reduction is occurring.

The de-esser works by momentarily decreasing the gain of the entire program. Recovery is so quick that vocal sounds surrounding the sibilance are essentially unaffected.

The de-esser is not a variable lowpass filter, and does not serve as a conventional high frequency limiter. Nevertheless, it has been found that it produces effects similar to a high frequency limiter on some program material, and can therefore sometimes be used to control high frequency overload on selected program material. It may be particularly useful in de-essing vocals which have already been

mixed with other program material; it performs this task significantly more smoothly than the Orban dedicated de-essers because its threshold does not follow the average input level.

It is important to critically audition any program material processed in this way to be sure that the control action does not produce unnatural pumping or modulation effects, since the perceived reduction of high frequencies is essentially a psychoacoustical illusion. (Strictly speaking, the frequency response is always "flat"; only the overall gain changes.)

Since the DE-ESSER OPERate/DEFEAT switch does not introduce clicks or discontinuities, it is quite practical to key the de-esser in and out as necessary to deal with certain "difficult" sections in the program.

Adjusting the OUTPUT ATTEN Control (rear panel)

In many cases the 424A is used to provide peak overload protection for a recording or transmission device.

Particularly when the OUTPUT TRIM control is used in conjunction with the VCA LEVEL meter to produce readings around 0dB (as described above), the peak output level of the 424A will be relatively constant. Therefore, best match between the 424A and such a protected device occurs at a gain which drives the device up to, but no further than, its optimum operating level. This gain need be adjusted only once for a given device. Adjustment may be effected either with the device's own input attenuator, or with the 424A's OUTPUT ATTENUator (located on the rear panel).

SOME SPECIFIC APPLICATIONS

Adjusting the 424A To Provide Peak Overload Protection

The typical "peak operating level" of an analog tape recorder is that level producing 3% total harmonic distortion; of a power amplifier, that level which drives the amplifier to its rated output voltage (power will vary according to load impedance); and of an STL transmitter, that level which drives the transmitter to 100% modulation.

The following procedure matches the 424A to the driven device. It assumes that the input attenuator of the driven device (if it exists) is fixed, and adjusted to produce approximately correct operating levels when driven by a +4dBm or +8dBm line. (If the driven device is significantly more sensitive, you may find that the 424A OUTPUT ATTENUATOR must be operated very close to its counterclockwise end stop, and may be touchy to adjust. In this case, it may be desirable to insert a loss pad between the 424A and the input of the driven device.)

First, you must decide if you will leave the control loop in its normal "bass rolloff" mode, or defeat the bass rolloff so that the control loop can sense the true peak level of the output. We recommend leaving the control loop in "bass rolloff" mode to achieve most natural sound, and to control any transient peak overshoots which may occur by permitting the VCA to clip them. However, if you wish to use the 424A as a fast-attack true-peak limiter, then you should restrap the control loop rolloff according to instructions provided in the **Control Loop Bass Rolloff** paragraph in **Part B** above.

After you have restrapped the control loop as necessary, apply a 400Hz sine wave oscillator to the input of the 424A. Switch both 424A OPERATE/DEFEAT switches to DEFEAT, and adjust the 424A INPUT ATTENUATOR and/or the oscillator output attenuator as necessary to produce a reading of "+2dB" on the VCA LEVEL meter.

This level is within 1dB of the clipping level of the VCA output. Adjust the 424A OUTPUT ATTENUATOR until the driven device is driven to the following level:

Analog Tape Recorder: 5dB above "Operating Level" (i.e., 5dB above the nominal 1% total harmonic distortion level).

Audio Power Amplifier: 1dB below clipping.

Studio-Transmitter Link Transmitter: 90% modulation if flat; 40% modulation if pre-emphasized at 50 or 75us. (NOTE: The 40% modulation figure may be increased if the de-esser is used to control occasional high frequency peaks. However, beware of possible audible side-effects if this is attempted!)

U.S.A. Standard Telephone Line: +16dBm into the line (through a Telco-supplied repeat coil). (NOTE: Place a 240 ohm $\pm 5\%$ 1/4 carbon film resistor in series with each leg of the 424A balanced output to assure that the phone line is driven by a true 600 ohm source impedance. The +16dBm must be measured on the phone line side of the resistors.)

Other Devices: 1dB below the nominal overload point if flat; if pre-emphasized, on the basis of experience.

Stereo And Multichannel Operation

The two channels of the 424A may be strapped by means of the INDEPendent/COUPLED switch to assure stereo tracking and stable imaging. In addition, any reasonable number of 422A's or 424A's can be tracked by respectively paralleling their rear-panel STEREO CPL and GATE CPL terminals. All compressor/limiter VCA's will then track the channel requiring the highest amount of gain reduction. Provided that the GATE THRESHold controls of all units are set identically, all units will remain ungated provided at least one unit receives sufficient input level to ungate. All operating controls are usually set identically.

The de-essers remain independent.

Speech-Activated Ducking of Music

Speech-activated ducking of music is one unusual capability which requires the use of two (or more) channels with the controls set in a unique way. In this broadcast-oriented application, the level of the music in the on-air mix is automatically reduced whenever speech is present.

A 424A or two 422A's, in COUPLED or strapped mode, must be used. Channel "A" is used for the speech, and Channel "B" for the music.

Apply the speech to Channel "A", and adjust the "A" operating controls to produce fast attack and release times, with the compressor/limiter OPerate/DEFEAT switch to OP. Set the "A" GATE THRESHold control OFF (fully CCW).

Apply the music to Channel "B", set its compressor/limiter OPerate/DEFEAT switch to DEFEAT, and set its IDLE GAIN control to "0". Adjust the "B" INPUT ATTENUator so that the VCA LEVEL meter never enters the red even on the highest peaks of the music.

Speech appearing at the CH "A" input at a level high enough to cause gain reduction in CH "A" will cause equivalent gain reduction in CH "B", thus ducking the music automatically during speech. The RATIO control determines if the music level is reduced in direct proportion to the speech level (high RATIO), or less than proportionately (low RATIO). The setting of the INPUT ATTENUator primarily determines the depth to which the music is ducked (the more gain reduction, the more ducking).

The outputs of the "A" and "B" channels (i.e., speech and music) may be mixed in an external mixer in any proportion desired. The original speech source may even be processed by another 424A with different settings, processed by other equipment, or left unprocessed.

By analogy, a similar setup can be used to modulate any signal by the envelope of any other signal. The range of the ATTACK and RELEASE TIME controls define the ability of this setup to track rapidly-varying envelopes.

Part D: Maintenance

Introduction: This part of the manual provides instructions on how to maintain the 424A, how to make sure that it is working according to specifications, and how to repair it if something goes wrong.

Factory service is available throughout the life of the 424A. Please refer to **Factory Service** subsection of **MAINTENANCE AND SERVICE** below for further information.

1: ALIGNMENT AND PERFORMANCE EVALUATION

General:

This procedure refers to the 424A (dual-channel version), but is equally applicable to the 422A (single-channel version). This section provides a series of thorough bench tests which will usually verify whether or not the 424A is operating normally. Certain subtle failures in the dynamic control circuitry cannot be detected by these tests, since special factory test procedures and equipment are necessary to fully characterize the dynamic operation of the 424A. Such subtle failures are usually detected by ear in the field, and factory service is recommended.

In the case of the dual-channel 424A, the completely redundant channels make "by ear" trouble diagnosis easier, as the bad channel can be directly compared with the good one.

The 424A is aligned as these tests are performed. The 424A has four trimmers per channel (which null thump and distortion, and standardize VCA gain). Alignment is ordinarily required only when IC5, IC6, IC7, IC8, or IC13 is replaced.

Power Supply:

Equipment Required:

- 1) VTVM or DVM
- 2) Oscilloscope

The following tests will verify correct operation of the Power Supply:

- 1) Using the DC voltmeter, measure the voltage from circuit ground to both positive and negative unregulated supplies. This can be readily measured across the two large filter capacitors. This voltage may be expected to vary widely depending on line voltage; it should measure between ± 18 and ± 26 volts DC.
- 2) Measure the voltage between circuit ground and the outputs of the positive and negative voltage regulators, IC5 and IC6. The supplies should put out between ± 14.25 and ± 15.75 VDC. If either supply exceeds 15.75 VDC, it implies that its associated IC regulator is defective. If either supply is lower than 14.25 VDC, refer to the **Power Supply** portion of **Part 3** in this section for troubleshooting hints.
- 3) Using the oscilloscope, measure the ripple and noise on the regulated positive and negative power busses. Ripple and noise should be less than 2mV peak on each bus.

Signal Processing Circuitry:

Equipment Required:

- 1) Oscilloscope with DC-coupled display
- 2) 20-20,000Hz bandpass filter, 18dB/octave slopes
- 3) VTVM or DVM
- 4) Harmonic distortion analyzer with built-in 400Hz and 80kHz filters and residual THD below 0.0015%
- 5) Low-distortion oscillator with residual THD below 0.0015%
- 6) OPTIONAL: General-purpose storage oscilloscope

(A Sound Technology 1700A or H-P 339 will satisfy (4) and (5))

For the following tests, a 600 ohm load must be provided across the 424A output. A 620 ohm 1/2 watt 5% carbon resistor is suitable.

IN THE CASE OF THE 424A, THE TEST PROCEDURE BELOW SHOULD BE FOLLOWED FROM BEGINNING TO END FOR CHANNEL "A", THEN REPEATED FOR CHANNEL "B".

1) Gain and Distortion Tests and VCA Alignment

- a) Connect the oscillator to the 424A input. Connect the THD meter/AC VTVM between the 424A (+) OUTPUT and circuit ground. Set the controls as follows:

INPUT ATTEN	10
RATIO	infinity
ATTACK TIME	5
RELEASE SHAPE	lin
RELEASE TIME	5
GATE THRESH	off
OUTPUT TRIM	0
IDLE GAIN	-25
COMP/LIM OP/DEFEAT	defeat
DE-ESSER OP/DEFEAT	defeat
DE-ESSER THRESH	"less"
OUTPUT ATTEN	fully clockwise
COUPLED/INDEP SWITCH	independent

- b) Verify that the GATED lamp is ON, indicating normal operation of the gating circuitry in the DEFEATED mode of the compressor.
- c) Set the oscillator frequency to 1kHz and its output level to -20dBm. Verifying that all of the control settings are as specified in (a) above, measure the output level of the 424A. Turn R60 (GAIN TRIM) counterclockwise until this level no longer decreases, indicating saturation of the VCA gain control circuitry. Then turn R60 clockwise until the output level of the 424A increases by 0.5dB.
- d) Set the IDLE GAIN control to "-10". Verify that the G/R METER reads 10dB G/R, ± 2 dB.
- e) **(424A only):** Temporarily switch the COUPLED/INDEP switch to COUPLED, and verify that the Channel B G/R METER also reads 10dB G/R, ± 2 dB. Restore the switch to INDEP.
- f) Set the oscillator frequency to 1kHz and advance its output level until the 424A VCA LEVEL meter indicates "-6".

- g) Measure the THD at the 424A output and adjust R26 (DISTORTION NULL) to minimize it. THD should not exceed 0.03% if measured using a 20-20kHz bandpass filter to minimize the effect of supersonic noise upon the distortion reading.
- h) Temporarily reduce the oscillator output level 10dB. Set the 424A IDLE GAIN control to "0", and verify that the 424A output level is increased 10dB \pm 2dB. Then restore the IDLE GAIN to "-10".
- i) Disconnect the oscillator from the 424A input, and connect it to the wiper of R64 (OUTPUT TRIM). Set the oscillator frequency to 100Hz, and adjust the oscillator output level until a distorted 100Hz feedthrough component can be seen on the scope monitoring the AC VTVM. Adjust R19 (THUMP NULL) to minimize the amount of feedthrough.
- j) Disconnect the oscillator from the wiper of R64. Connect the DVM to the output of IC9B. Adjust R28 (DE-ESSER THUMP NULL) to secure a reading of 0VDC.

2) Noise Test

- a) Suppress the oscillator and turn the 424A INPUT ATTEN to "0". Measure the noise at the 424A output through a 20-20kHz bandpass filter with 18dB/oct or greater slopes. The noise should not exceed -68dBm.

NOTE: If this specification is not met, be sure that hum or RF pickup due to poor test equipment configuration or grounding is not causing falsely high readings.

3) De-esser Operation

- a) Verify that the de-esser THRESHOLD control is set at "less", and that the de-esser OP/DEFEAT switch is DEFEATED.
- b) Set the oscillator frequency to 10kHz, and set its level to produce +12dBm at the 424A output.
- c) Switch the de-esser OP/DEFEAT switch to OP, and verify that the 424A output level is reduced to +6dBm, \pm 1dB.
- d) Verify that the NORM de-essing lamp is ON. Adjust the de-esser THRESHOLD control clockwise, and verify that the HEAVY de-essing lamp comes on when the control is set at approximately "4".
- e) Adjust the 424A de-esser THRESHOLD control to "more". Switch the oscillator frequency to 3kHz, and verify that the 424A output level becomes +8.0dBm, \pm 1dB.
- f) Switch the de-esser OP/DEFEAT switch to DEFEAT.

4) Compressor/Limiter Operate Mode Tests

- a) Suppress the oscillator output. Verify that the GATE THRESH control is OFF. Switch the COMP/LIM OP/DEFEAT switch to OP, and verify that the G/R meter recovers to "0".
- b) Set the oscillator frequency to 100Hz, and advance the oscillator output level until the 424A G/R meter reads 20dB G/R. Measure the THD at the 424A output, and verify that it is less than 0.05%. Observe the distortion output from the THD analyzer on a scope, and verify that the distortion residual looks like Fig. D-1. Suppress the oscillator output, and verify that the time required for the G/R meter to move from 20dB to 10dB G/R is 2.0seconds, \pm 0.5seconds.

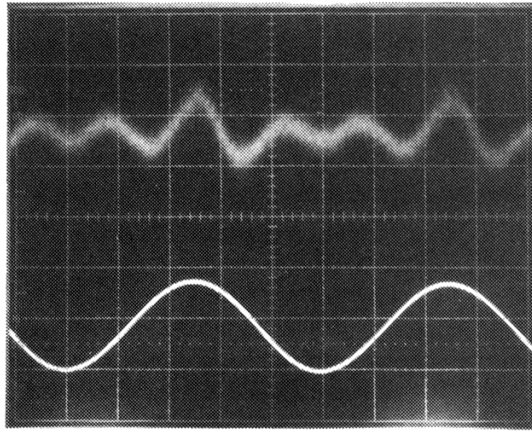

Fig. D-1: 100HZ DISTORTION RESIDUAL, LIN RELEASE

- c) Restore the oscillator output. Switch the RELEASE SHAPE switch to EXP, and verify that the distortion decreases, and that the distortion residual looks like Fig. D-2. Suppress the oscillator output, and verify that the time required for the G/R meter to move from 20dB to 10dB G/R is 2.0seconds, ± 0.5 seconds.

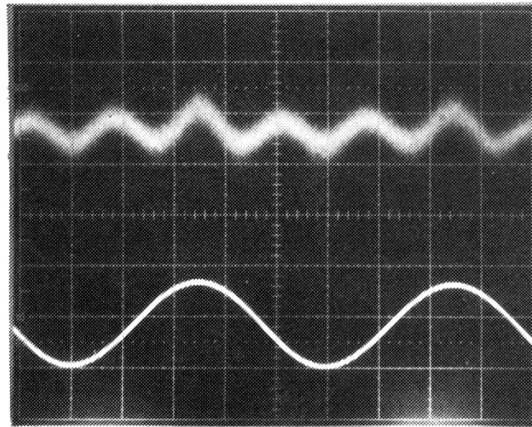

Fig. D-2: 100HZ DISTORTION RESIDUAL, EXP RELEASE

NOTE

The shape of the distortion residual provides a good indication of whether the timing module and other circuitry within the control loop are operating properly. If the distortion residual which you observe is significantly different than the Figures (particularly if accompanied by audible problems with sound quality), we recommend returning the 424A for factory service, as it is usually impractical to diagnose and repair subtle control circuitry problems in the field.

5) COMPRESSION RATIO control test

- a) Set the 424A ATTACK TIME control to "0" (FAST), and the RATIO control to "infinity". Set the oscillator frequency to 1kHz, and its output to produce 10dB G/R. Adjust the OUTPUT TRIM control as necessary to produce +11.0dBm at the 424A output. (The OUTPUT TRIM control should be within 2dB of "0" after you have done this.)
- b) Set the RATIO control at each of the panel markings in **TABLE D-1**, and verify that the 424A output level is close to the values indicated, ± 1 dB.

<u>Ratio</u>	<u>Output Level</u>
infinity	+11.0dBm
6:1	+8.8dBm
4:1	+8.0dBm
3:1	+7.6dBm
2:1	+8.2dBm

**TABLE D-1
RATIO CONTROL TEST**

6) ATTACK TIME control and threshold circuitry test

- a) Without changing other control settings, restore the RATIO control to "infinity". The G/R meter should read "10dB".
- b) Adjust the attack time control to the settings shown in **TABLE D-2**, and verify that the 424A output level approximately corresponds to the values shown in the Table, ± 1 dB.
- c) Restore the ATTACK TIME control to "0", and adjust the OUTPUT TRIM control between "0" and "-10". Verify that the G/R meter stays between 9 and 11dB G/R as this is done. When you are through, restore the OUTPUT TRIM control to "0".

<u>Attack Time</u>	<u>Output Level</u>
"fast"	+11.0dBm
"2"	+7.6dBm
"4"	+5.0dBm
"6"	+4.5dBm
"8"	+3.8dBm
"slow"	+0.5dBm

**TABLE D-2
OUTPUT LEVEL VS ATTACK TIME TEST**

7) GATING Circuitry Test

- a) Temporarily suppress the oscillator output. Turn the GATE THRESHold control fully counterclockwise, and verify that the GATED lamp is OFF. Then rotate the control clockwise, and verify that the GATED lamp lights at approximately "3". Turn the control counterclockwise, and verify that the GATED lamp goes out at approximately "2".
- b) Restore the oscillator output to the level required to produce 10dB gain reduction. Then reduce its level by 20dB. Starting fully counterclockwise, rotate the GATE THRESHold control clockwise until the GATED lamp lights. Verify that this occurs at approximately "5" on the dial.
- c) **(424A only): (Note:** These instructions apply when you are testing Channel A. When you are testing Channel B, exchange all of the "Channel A" and "Channel B" references in this paragraph.)
Without applying signal to the input of Channel B, adjust the Channel B GATE THRESHold control to "5". Place the Channel B COMP/LIM OP/DEFEAT control in OP, and verify that the Channel B GATED lamp lights. Now increase the output of the test oscillator connected to the Channel A input until the Channel A GATED lamp goes out. Switch the COUPLED/INDEP switch to COUPLED, and verify that the Channel B GATED lamp goes out. Restore the switch to INDEP, and verify that the Channel B GATED lamp comes on again.

8) OPTIONAL verification of LIN and EXP release

- a) Connect the vertical input of a storage scope to the rear-panel STEREO COUPLE terminal. This monitors the gain of the VCA, and is scaled such that each dB of gain reduction changes the voltage by $-0.4V$.
- b) Operate the scope at $1V/div$ vertical and approximately $0.2sec/div$ horizontal. Switch the RELEASE SHAPE switch to LIN and make sure that the GATE THRESH is OFF. Apply a level from the oscillator to the 424A input terminals sufficient to make the 424A G/R meter read "20dB". This should produce a voltage at the STEREO COUPLE terminal of approximately $-8.0V$.
- c) Suppress the oscillator output, and observe the control voltage with the scope as it releases. It should create a straight line until $-0.3V$ has been reached, at which point the line will become much more horizontal. Do not erase the trace; it will be superimposed with another trace in the next step.
- d) Switch the RELEASE SHAPE switch to EXP. Restore the oscillator and verify that the G/R meter once again reads "20dB". Suppress the oscillator and superimpose the control voltage release shape upon the LIN shape measured in step (c) above. When superimposed, the two traces should look like Fig. D-3.

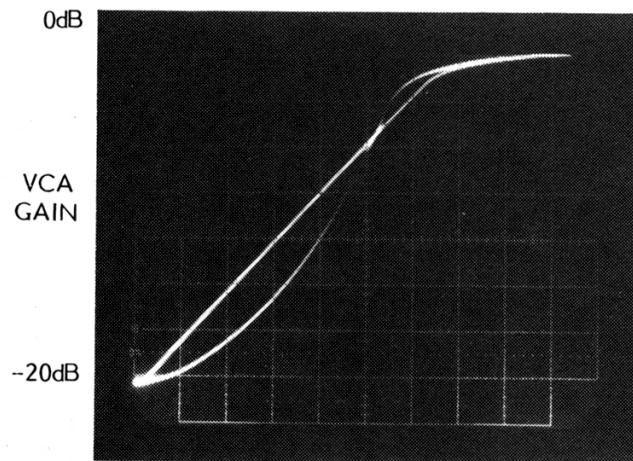

Fig. D-3: LIN and EXP Release Shapes

2: MAINTENANCE AND SERVICE

Preventive Maintenance

The front panel may be cleaned with a mild household detergent. Stronger solvents should be avoided, as they may damage the paint, the silk-screened lettering, or the plastic control knobs.

Corrective Maintenance

All Orban products are designed to be completely free of failures throughout eternity. However, Orban research has recently discovered that there is no justice in the world, and, in fact, there is not supposed to be any.

For this reason, the following **Corrective Maintenance** section is included.

CAUTION

Repairs made to this product should be performed in accordance with applicable safety standards for your country, and should be performed only by a well-qualified, professionally-trained service technician.

Service Access

Access to the 422A/424A for service and adjustment is relatively straightforward.

The 422A contains only one card, and full access is obtained by removing the top and bottom covers.

In the 424A, each channel has its own horizontally-mounted circuit card. These are stacked, so direct access to the bottom of the CHANNEL A board or the top of the CHANNEL B board requires a certain amount of disassembly beyond removing the top and bottom covers. However, all alignment trimmers can be accessed by cover removal alone, since the CHANNEL B alignment trimmers are mounted on the bottom of the CHANNEL B board, whereas the CHANNEL A trimmers are mounted on the top of the CHANNEL A board.

Full access to one board in the 424A requires removal of the other board. This is done as follows:

- 1) **Knob Removal:** Pry the plastic cap off the front of each knob. Using the wrench supplied with the packing materials, turn the now-exposed collet counterclockwise until the knob pulls off the pot shaft easily. (If you have lost the wrench, a screwdriver will probably work.)
- 2) **LED Removal:** Grasping the leads, gently pull each LED out of its plastic lens.
- 3) **Meters:** Disconnect the tab terminals from each of the two meters, noting which tab goes to which terminal for later reassembly.
- 4) **Board Access:** Remove eight machine screws from the edges of the board. Slide the board about 3/4" (19mm) backward to assure that the pot shafts clear the front panel. Then tilt the board outward, imagining a hinge at the rear edge.
- 5) **Complete Board Removal:** If you want to entirely remove a board, the various interconnections must be unsoldered.

In the 424A, power is supplied from the CHANNEL A board to the CHANNEL B board through a plug which is simply pulled off. In addition, the two boards are interconnected by means of wire leads connected to the COUPLED/INDEP switch. The two wires may be unsoldered at the COUPLED/INDEP switch, noting which wire goes to which terminal. (This switch is soldered to floating pads on the board to secure it mechanically. However, it does not connect to any printed wiring.)

Reassembly is performed in the reverse of disassembly. (If notations as to which wire goes to which terminal are misplaced, consult the schematic at the back of this manual to deduce the correct wiring.)

Circuit boards should be fastened using eight screws removed above, taking care to center the switch shafts in their holes to avoid binding.

When the knobs are reattached, they should first be partially tightened, leaving a small clearance between the knob and the panel. Once partially tightened, each knob should be turned so that it aligns with the markings on the panel at the counterclockwise stop of the pot.

Once properly aligned, each knob should be firmly tightened. Then replace the snap-on caps, accurately aligning the marking on the cap to the marking on the knob.

The meters should be reconnected as necessary, and the LED's reinserted in their color-coded lenses.

Operation of the unit should be checked before the covers are installed.

Lamp Replacement: Lamps supplied with the 422A/424A are a long-life type which are operated below their rated voltage. They are not expected to fail in the field under normal circumstances. If they do fail, replacement requires removing the meter bracket after removing one circuit board. The correct replacement is a #1847 lamp; a #47 lamp may be substituted in an emergency, although its life is shorter and it may therefore require inconvenient future replacement. (If one lamp is replaced, it may be advisable to replace the other to avoid future work.)

Component Replacement: All IC's in the unit are socketed and can be readily replaced from the top surface of each board. Realignment is required if IC5, IC6, IC7, IC8, or IC13 is replaced.

Other components are soldered in place, and may be replaced following the instructions in **Replacement of Components On Printed Circuit Boards** immediately below.

The two potted modules on each board are not field-repairable, and must be replaced in their entirety. While either module can be replaced without realignment of the unit, diagnosing failures in the Compressor/Limiter Timing Module can be tricky and is best left to the factory unless you are willing to risk the expense of replacing a possibly good module!

If filter capacitors are to be replaced, fasten them securely to the board, using the original factory installation as a model. This will prevent their breaking loose in the future from vibration.

Replacement Parts: If you have difficulty finding parts for this or any other Orban product, Orban Customer Service stands ready to supply you with the required parts at a fair price. Please call us at the telephone number shown at the front of this Manual.

Replacement of Components on Printed Circuit Boards

It is important to use the correct technique for replacing components mounted on PC boards. Failure to do so will result in possible circuit damage and/or intermittent problems.

The circuit boards used in the 424A are of the double-sided plated-through variety. This means that there are traces on both sides of the board, and that the through-holes contain a metallic plating in order to conduct current through the board. Because of the plated-through holes, solder often creeps 1/16" up into the hole, requiring a sophisticated technique of component removal to prevent serious damage to the board.

Removal: If the technician has no practical experience with the elegant and demanding technique of removing components from double-sided PC boards without board damage, it is wiser to cut each of the leads of an offending component from its body while the leads are still soldered into the board. The component is then discarded, and each lead is heated independently and pulled out of the board with long nose pliers. Each hole may then be cleared of solder by carefully heating with a low-wattage soldering iron and sucking out the remaining solder with a spring-activated desoldering tool. **THIS METHOD IS THE ONLY SATISFACTORY METHOD OF CLEARING A PLATED-THROUGH HOLE OF SOLDER!**

Another technique is:

- 1) Use a 30 watt soldering iron to melt the solder on the solder (underneath) side of the PC board. Do not use a soldering gun or a high-wattage iron! As soon as the solder is molten, vacuum it away with a spring-actuated desoldering tool like the Edsyn "Soldapullit". **AVOID OVERHEATING THE BOARD;** overheating will almost surely damage the board by causing the conductive foil to separate from the board. Use a pair of fine needle-nose pliers to wiggle the lead horizontally until it can be observed to move freely in the hole.
- 2) Repeat step (1) until each lead to be removed has been cleared of solder and freed.
- 3) Now lift the component out.

Installation:

- 1) Bend the leads of the replacement component until it will fit easily into the appropriate PC board holes. Using a good brand of rosin-core solder, solder each lead to the bottom side of the board with a 30 watt soldering iron. Make sure that the joint is smooth and shiny. If no damage has been done to the plated-through hole, soldering of the topside pad is not necessary. However, if the removal procedure did not progress smoothly, it would be prudent to solder each lead at the topside as well in order to avoid potential intermittent problems.
- 2) Cut each lead of the replacement component close to the solder (underneath) side of the PC board with a pair of diagonal cutters.

- 3) Remove all residual flux with a cotton swab moistened with a solvent like 1,1,1 trichloroethane, naphtha, or 99% isopropyl alcohol. The first two solvents are usually available in supermarkets under the brand name "Energine" fire-proof spot remover and regular spot remover, respectively. The alcohol, which is less effective, is usually available in drug stores. Rubbing alcohol is highly diluted with water and is ineffective.

It is good policy to make sure that this defluxing operation has actually removed the flux and has not just smeared it so that it is less visible. While most rosin fluxes are not corrosive, they can slowly absorb moisture and become sufficiently conductive to cause progressive deterioration of performance.

Troubleshooting IC Opamps

IC opamps are usually operated such that the characteristics of their associated circuits are essentially independent of IC characteristics and dependent only on external feedback components. The feedback forces the voltage at the (-) input terminal to be extremely close to the voltage at the (+) input terminal. Therefore, if the technician measures more than a few millivolts between these two terminals, the IC is probably bad.

Exceptions are IC's used without feedback (as comparators) and IC's whose outputs have been saturated due to excessive input voltage because of a defect in an earlier stage. Also, be sure that the voltmeter is not interacting with these sensitive points and affecting the measured voltage. However, if an IC's (+) input is more positive than its (-) input, yet the output of the IC is sitting at -14 volts, this almost certainly indicates that it is bad. The same holds if the above polarities are reversed.

Because the characteristics of the 424A are essentially independent of opamp AC characteristics, an opamp can usually be replaced without need for recalibration. However, most of the circuitry in the compressor/limiter control loop is sensitive to opamp DC characteristics, like bias current and offset voltage. Because of this, high-performance dual opamps are used in many sockets. These devices must be replaced by exact replacements.

NOTE

The dual current-controlled gain block IC5 used in the VCA is not an opamp. If it is replaced, recalibration according to the instructions in **Part I** of this **MAINTENANCE** section is absolutely necessary.

A defective opamp may appear to work, yet it may have extreme temperature sensitivity. If parameters appear to drift excessively, freeze-spray may aid in diagnosing the problem. Freeze-spray is also invaluable in tracking down intermittent problems. But, use sparingly, because it can cause resistive short circuits due to moisture condensation on cold surfaces.

Factory Service

Please refer to the terms of your Orban Associates Limited One-Year Standard Warranty, which extends to the first end-user. This warranty was packed with the 424A but is not bound with this manual. After expiration of the warranty, a reasonable charge will be made for parts, labor, and packing if you choose to use the factory service facility. Repaired units will be returned C.O.D. In all cases, transportation charges (which are usually quite nominal) shall be borne by the customer.

After a formal Return Authorization number is obtained from the factory, units should be shipped to CUSTOMER SERVICE at the address shown on the front page of this manual.

YOUR RETURN AUTHORIZATION NUMBER MUST BE SHOWN ON THE LABEL,
OR THE PACKAGE WILL NOT BE ACCEPTED!

Shipping Instructions

If the original packing material is available, it should be used. Otherwise, a carton of at least 200 pounds bursting test and no smaller than 22" x 15" x 9" should be employed.

The 424A should be packed so that there is at least 1-1/2" of packing material protecting every point. A plastic wrap around the chassis will protect the finish. Cushioning material such as Air-Cap, Bubble-Pak, foam "popcorn", or fibre blankets are acceptable. Folded newspaper is not suitable. Blanket-type materials should be tightly wrapped around the 424A and taped in place to prevent the unit from shifting out of its packing and contacting the walls of the carton.

The carton should be packed evenly and fully with the packing material filling all voids such that the unit cannot shift in the carton. Test for this by closing but not sealing the carton and shaking vigorously. If the unit can be felt or heard to move, use more packing.

The carton should be well-sealed with 3" reinforced sealing tape applied across the top and bottom of the carton in an "H" pattern. Narrower or parcel-post type tapes will not stand the stresses applied to commercial shipments.

The package should be marked with the name of the shipper, and the words in red: DELICATE INSTRUMENT, FRAGILE! Even so, the freight people will throw the box around as if it were filled with junk. The survival of the unit depends almost solely on the care taken in packing!

3: CIRCUIT DESCRIPTION

General: Except for the power supply, the "A" and "B" channels of the dual-channel 424A are independent and identical.

The circuitry is divisible into six major blocks. These are:

- 1) input buffer
- 2) voltage-controlled amplifier
- 3) compressor/limiter control circuitry
- 4) de-esser control circuitry
- 5) VCA LEVEL meter driver
- 6) power supply

These will be described in order.

1) Input Buffer

The signal enters the 424A in balanced form. C1, C2 shunt RF from the input leads to the chassis. These capacitors are not effective at VHF and higher frequencies; therefore, ferrite beads have been placed around the input and output leads to suppress such high frequency RF. It should be noted that this degree of RF-proofing is moderate but adequate for a vast majority of installations. However, installation next to a high-power transmitter may still cause problems. Additional RF suppression, careful examination of the grounding scheme, and other considerations familiar to the broadcast engineer may have to be used in conjunction with the 424A's built-in RF suppression.

The filtered signal is applied to IC2, a very low-noise opamp configured as a differential amplifier with a gain of 1. When both non-inverting and inverting inputs are driven by a source impedance which is small with respect to 100K (such as 600 ohms or less), the amplifier is essentially insensitive to signal components that appear equally on the non-inverting and inverting inputs (such as hum), and responds with full gain to the difference between the non-inverting and inverting inputs. Thus it serves as an "active transformer". Ordinarily, best results are obtained for unbalanced signals if the non-inverting input is grounded and the inverting input is driven.

The GAIN control is located after IC2. Therefore, IC2 will overload if its differential input exceeds approximately +20dBm.

2) Voltage-Controlled Amplifier (VCA) Operation

Current-Controlled Gain: The current-controlled gain block used in the 424A is a proprietary Class-A VCA which operates as a two-quadrant analog divider with gain inversely proportional to a current injected into a first gain-control port, cascaded with a two-quadrant analog multiplier with gain directly proportional to a current injected into a second gain-control port. For most gains, levels, and frequencies, THD is well under 0.1%. Overload-to-noise ratio (noise measured in a 20-20,000Hz band) is typically 90dB, and is constant with respect to gain and level.

A specially-graded Orban IC contains two matched non-linear gain-control blocks with differential inputs and current outputs. If used alone, one such gain-control block would introduce considerable distortion. Therefore, the first of the two matched blocks IC13A is used as the feedback element in a high-quality operational amplifier, IC14. The second of the matched blocks IC13B is then driven by the predistorted output of IC14. To provide more detail: The output of IC14 is first attenuated by R20, R21, C9, and then applied to the input of the feedback element IC13A. The output of IC14 is predistorted as necessary to force the current output of IC13A to precisely and linearly cancel the audio input into the "virtual ground" summing junction of IC14. This same predistorted voltage is also connected to the input of IC13B. Thus the output of IC13B is an undistorted current. This current is converted to a voltage in current-to-voltage converter IC9B, R22, C10. The output of IC9B is the output of the VCA.

Because IC13A is in the feedback loop of IC14, the gain of the VCA is inversely proportional to the gain of IC13A. Thus if the control current is applied to the control port of IC13A (from Q1), then the VCA behaves like a two-quadrant analog divider. The gain-control current injected into this control port is developed by the compressor/limiter control circuitry.

A current developed from the de-esser control loop is injected into the control current port of IC13B. The gain of IC13B is directly proportional to its control current. The de-esser function results from varying this control current. The de-esser function is functionally in series with the output of the compressor/limiter and does not affect its operation, since the feedback signal to activate the compressor limiter is taken from the output of IC14, which is unaffected by the gain of IC13B.

Second-harmonic distortion is introduced by differential offsets in either IC13A or IC13B. This distortion is cancelled by applying a nulling voltage directly to the input of IC13B by means of resistor network R24, R25, R26.

If the VCA is not perfectly balanced, "thumps" due to control current feedthrough can appear at the output. These are equivalent to multiplying the control current by DC. If a correct DC offset is applied to the VCA input, then this equivalent DC multiplication can be nulled to zero and the "thumps" eliminated. Such an adjustable DC offset is provided by R17, R19.

C8, R18 are frequency-compensation components to prevent the VCA from oscillating supersonically.

"Thumps" can also appear due to de-esser control current feedthrough at IC13B's output. Nulling compressor feedthrough by means of R19 may make de-esser feedthrough worse. Therefore, a separate de-esser feedthrough null circuit consisting of IC8B-E, R27, R28 is included.

The de-esser control current flows from the collector of IC8A. A current identical to the de-esser control current flows from the collector of IC8B, since IC8A and IC8B are matched transistors. The current output of IC8B is inverted in current mirror IC8C-E, and injected into the junction of R27 and R28, where it develops a voltage. The voltage is amplified in both inverting and non-inverting modes by IC9B. When the wiper of R28 is at 50% rotation, then IC9B's inverting and non-inverting gains are equal, and no effect is produced at IC9B's output due to cancellation. Moving the wiper of R28 to either side of this null point permits introduction of sufficient control voltage into IC9B's output to cancel any feedthrough in IC13B, regardless of the feedthrough's polarity.

Exponential Converter: The basic current-controlled gain in the compressor/limiter is inversely proportional to the control current. We wish to transform this into a gain which is proportional to a control voltage in dB. This is done in the exponential current converter consisting of IC12B and associated components.

IC12B, IC7A, IC7B, IC7C and associated components form a log/antilog multiplier. This multiplier multiplies the current flowing in R63 by the exponential of the voltage on the base of IC7B. The current gain of the multiplier increases as the voltage on the base of IC7B becomes more negative.

Because the voltage on the base of IC7B is in log (i.e., dB-linear) form, various control voltages can be summed into this base, and they will add in a dB-linear manner. These control voltages include the main gain-control output of the timing module (through R62), a gain trim (through R61), and the user-adjustable OUTPUT TRIM (through R65) which adjusts not only the gain of the VCA, but the compression threshold as well, as will be described below.

The current output of the log/antilog multiplier appears on the collector of IC7A. It is the wrong polarity and level to correctly drive the control-current port of IC13A. It is therefore applied to a current inverter IC12A, Q1, R57, R58, C21. This circuit has a gain of 6.66x, and operates as follows:

A voltage proportional to the current output of IC7A is developed across R58 because of the feedback action of IC12A. (C21 stabilizes IC12A against oscillations.) Feedback forces IC12A's (-) and (+) inputs to be at the same voltage. Thus, the same voltage which appears across R58 also appears across R57, and current flows in R57 in proportion to the ratio between the values of R58 and R57.

This current flows out of the (+) input line of IC12A into the emitter of Q1. Because Q1's base current is small compared to its emitter current, essentially the same current flows out of Q1's collector into the gain-control port of IC13A.

The base of Q1 is grounded; its emitter therefore sits at +0.6V. This forces both (+) and (-) inputs of IC12A to also sit at +0.6V, and assures correct bias voltage for IC7A's collector.

CR9 protects Q1 from reverse base-emitter voltage which could otherwise cause junction breakdown and latchup of the entire current-inverter circuit.

3) Compressor/Limiter Control Circuitry

General: The compressor/limiter is a feedback circuit. That is, the gain-controlled output of the compressor/limiter is sensed, and is used to develop a gain-control signal which is applied to the compressor/limiter gain-control port of the VCA.

This arrangement results in superior stability of characteristics with time and temperature, extremely low distortion, and optimized control-loop dynamic response.

Rectifier With Threshold: The output of IC14 in the VCA is applied to a rectifier with threshold. This circuit has a current input and current output. Its current gain is adjustable with R79, the ATTACK TIME control.

IC14's output is gain-controlled but predistorted, and its peak level rises faster than the peak level of the VCA output as VCA clipping is approached. Using this signal as the control source to the rectifier makes the compressor/limiter circuit automatically resist VCA clipping, as the error signal used in the feedback control loop becomes rapidly larger as clipping is approached, thus effectively speeding the attack time and reducing overshoots at the VCA output.

Any DC offsets at IC14's output are blocked by C24. Network R85, C23 provides a highpass shelving rolloff in the bass, making the control circuit less sensitive to bass. This matches the equal-loudness curves of the ear (the ear is less sensitive to bass than to midrange frequencies), and prevents obvious modulation of midrange material by bass. A jumper is available to defeat this rolloff if the 424A is to be used as a true peak limiter which must be equally sensitive to all frequencies.

The output of the shelving network is applied to a conventional precision halfwave rectifier IC10B, R84, R83, CR26, CR27. The output of this rectifier (which inverts its input) is applied to the summing junction (a virtual ground) of IC10A through R81 with a relative gain of 2x. The input of the half-wave rectifier is also applied to IC10A's summing junction through R82, with a relative gain of 1x. The current input to IC10A's summing junction is thus a full-wave rectified signal with a relative gain of 1x.

When there is no output from rectifier IC10B, threshold current is removed from the IC10A summing junction through R80. This current flows through CR25, and IC10A's external PNP output transistor (pins 10, 11, and 12 of IC3) is turned off. When the current output from the rectifier exceeds the threshold current, CR25 turns off and the output transistor is turned on through CR24, thus permitting output current to flow from the circuit into the following timing module.

R80 (through which the threshold current is removed) is fed from the output of IC1A, which supplies a threshold voltage which is varied in ways which will be described below. For the moment, observe that adjusting R79a will vary the amount of current removed from IC10A's summing junction, thus lowering the compression threshold when the attack time is lengthened.

IC10A and associated components are essentially a current-in, current-out circuit with adjustable current gain. The current input is IC10A's (-) input; the current output of the circuit is the collector of IC10A's output transistor. This output current is further applied to a three-transistor Wilson current mirror within IC3 which inverts and level-shifts the current so that the final output current flows from pin 9 of IC3 into the timing module.

The output current of the circuit is essentially equal but opposite to the current flowing into the emitter of IC10A's output transistor. This current is the sum of the current flowing through R75 and the current flowing through the R75 side of R79a.

When the wiper of R79a is far from R75, IC10A (through its output transistor) behaves like a high-gain inverting amplifier, forcing a considerable voltage drop across R75, and therefore resulting in a high current through R75 and high current gain in the circuit. This corresponds to a fast attack time.

As the wiper of R79a is moved closer and closer to R75, the inverting gain decreases and the attack time lengthens. Simultaneously, the threshold decreases. When the wiper of R79a is almost at, or at its R75 endstop, a minimum current gain of approximately 1x is achieved.

At this point, the offset introduced into the (+) input of IC10A by voltage divider R77, R78 (as fed by the threshold voltage) comes into play to swiftly and radically lower the rectifier threshold by causing a current flow through R75 which almost balances the current flow out of R80. This keeps the peak output level of the compressor/limiter approximately constant, as extremely slow attack times are rather abruptly produced as R79a's wiper comes close to the R75 endstop, and these attack times must be complemented by large decreases in threshold.

It should be noted that IC10A must have offset of less than 1mV for this scheme to work reliably, and it is therefore important to replace IC10A by an identical IC in case of failure.

Timing Module: Pin 9 of IC3 feeds the compressor/limiter timing module. This module contains proprietary circuitry which receives the input current from the rectifier with threshold, and outputs a control voltage with appropriate dynamics to achieve natural-sounding control and very low modulation distortion. The output of the module is a low-impedance unidirectional voltage source which can be wire-"OR"ed with other such modules to effect stereo tracking of an arbitrary number of channels.

The RELEASE TIME control R68 allows a 20:1 variation in the basic release dynamics, which are determined by the timing module on the basis of the past history of the input. When the gating FET Q4 is turned OFF by pulling its gate towards +15 volts, voltage is forced into the timing module from the IDLE GAIN control R72 through R70. The setting of this control determines the output voltage of the timing module under gated conditions.

When the COMP OPERate/DEFEAT switch is DEFEATED, the same voltage is forced into the module through a smaller resistor R69, and the module output voltage quickly approaches the voltage at the wiper of the IDLE GAIN control.

A sample-and-hold circuit is associated with the timing module. The sample and hold provides a reference for the circuit in EXP release shape mode (it essentially tells the circuit where the release started). Each time IC10A turns its output transistor ON, it also turns on the switching transistor in IC3 (pins 13, 14, and 15). This pulls pin 15 to ground, and pulls the gate of Q5 to ground, turning Q5 ON and capturing a sample of a control voltage on C27. This is buffered by IC11A and fed back to the timing module through a resistor network and the RELEASE SHAPE switch S1.

A second section of the ATTACK TIME control R79b is provided to slow the release time at very slow attack times, lest the release become faster than the attack and severe inaccuracies occur in the compression ratio. R79b is buffered by IC17A, the output of which is fed into the resistor network associated with S1.

Other details of the operation of the circuit and how it interacts with the timing module are beyond the scope of this manual.

Threshold-Setting Circuitry and RATIO Control: As was explained above, the compression threshold is modified by the setting of R79 in order to lower the threshold as the attack time is lengthened.

The threshold is modified by three other factors.

The first factor is the gain of the COMPRESSION RATIO control R92. The basic compressor circuit has a high compression ratio (approaching infinity-to-one). To achieve lower compression ratios, the VCA gain-control voltage is fed back into the threshold circuit through R91 and R92 in such a way as to increase the threshold as more gain reduction occurs. The amount of feedback is adjusted by R92 from none (infinity-to-one) to enough to produce a 2:1 ratio at compression threshold. It can thus be seen that the compressor output level increases as gain reduction increases, lowering the compression ratio as desired. (Because of details of the circuit configuration, all ratios increase as gain reduction increases beyond threshold, yielding a "soft knee" curve.)

The second factor is the position of the COMPRESSION RATIO control R92. The network R88, R89, R90, R91, R92 provides a bias current for IC1B which in turn determines the basic compression threshold. This bias current is decreased as R92 is turned counterclockwise towards lower ratios, thus lowering the threshold and increasing the gain reduction to avoid potential VCA overload as its output level increases.

The circuit has been designed so that at 25dB (maximum achievable) gain reduction, the VCA output is approximately constant regardless of the position of R92. The change in VCA gain-control voltage fed into the circuit through R91 approximately compensates for the change in current flowing through R90 and R88 as the loading on these resistors is changed by adjustment of R92.

The third factor is the OUTPUT TRIM control R64. This adjusts the gain of the VCA and simultaneously adjusts the compression threshold to keep the amount of gain reduction approximately constant.

R64's wiper is coupled to the VCA gain port through R65, and to the gain-control input of log/antilog multiplier IC1 (and associated components). The input to the multiplier is the current output of the RATIO control and associated network discussed above. The multiplier varies its gain (and thus the threshold voltage) by 20dB as R64 is adjusted throughout its range. The gain of the VCA is simultaneously adjusted by 20dB, so that the VCA's output varies by 20dB but the amount of gain reduction stays approximately constant.

(NOTE: Because the compressor/limiter control loop "looks at" the predistorted output of IC14 rather than the actual output level of the VCA (at IC9B), when attempting to increase gain with R64, you will observe that the VCA output level does not necessarily increase in proportion to the control calibrations. You will note that instead, the gain reduction increases due to the non-proportional increase in the peak output level of IC14 compared to the output level of the VCA. This circuit feature helps the system resist clipping as the VCA overload point is approached.)

The output of the multiplier is the output of IC1A, which feeds the ATTACK TIME control as discussed above. It can thus be seen that all of the many other threshold modifications discussed above in association with the ATTACK TIME and RATIO controls are scaled proportionately by the action of the multiplier, as desired.

Gating Circuitry: The gating detector monitors the level of the 424A input signal, and activates the gate if said level drops below a threshold adjustable with the GATE THRESH control R14. The gate is activated when the output of IC18B is positive, and defeated when it is negative.

The input level detector is a half-wave positive peak detector, and consists of IC18A and associated components. The input line is connected to the (+) input of IC18A. IC18A's output charges C7 through CR1 and R6. The voltage across C7 is fed back to IC18A's (-) input through voltage divider R7, R8, which also serves to discharge C7 in the absence of signal, thus determining the recovery time of the detector.

The choice of components yields a DC detector gain of approximately 22x.

The voltage at C7 (representing 22x the positive peak value of the 424A input signal after the INPUT ATTEN) is applied to the (-) input of IC18B, operated as a comparator with hysteresis. The comparator threshold is a voltage developed at IC18B's (+) input through resistor network R9, R11, R12, R13, R14. When the voltage at IC18B's (-) input is lower than the voltage at its (+) input, IC18B's output goes positive and the gate turns on. Feedback for hysteresis is provided through R11. The positive threshold voltage at IC18B's (+) input is adjusted by means of R14. R9 is connected to the -15 volt supply, and assures that turning R14 fully counterclockwise will force the voltage at IC18B's (+) input slightly negative, thus turning the gating function off since the voltage across C7 (applied to IC18B's "-" input) can never go negative.

Under gated conditions, Q4 is pinched off by pulling its gate to a high positive voltage through CR22. This opens the RELEASE TIME path and permits the IDLE GAIN control R72 to inject a voltage into R70 which forces the output voltage of the timing module to drift towards the voltage at the wiper of the IDLE GAIN control.

Under ungated conditions, CR22 is OFF, Q4's gate is clamped to the same voltage as its source through R74, and Q4 becomes equivalent to a low resistance. Since Q4's source is driven from a low impedance, the effect of the IDLE GAIN control is entirely swamped out, and the RELEASE TIME control is permitted to conduct normally.

Gain Reduction Meter: The gain-control voltage at the output of the timing module is fed to a peak-detector circuit (consisting of IC16 and associated components) which in turn drives the gain reduction meter.

The gain-control voltage is applied to the (+) input of IC16B. The output of IC16B drives a peak detector network C16, C17, CR10, CR11, CR12, CR13. When IC16B's (+) input goes more negative than its (-) input (indicating that the output of the meter driver circuit needs to be updated), IC16B's output goes negative and charges both C16 and C17 to approximately equal voltages through CR10 and CR13. IC16B's output stays negative and continues charging until C16 is charged to the negative peak value of the gain control voltage. IC16A, configured as a voltage-follower, buffers C17 and provides a negative feedback voltage for IC16B.

As long as C16 is charged to a more negative voltage than is present on the (+) input of IC16B, the output of IC16B will be positive, turning off both CR10 and CR13 and permitting C16 to discharge towards ground through R44 and R45. As C16 discharges, the voltage differential between C16 and C17 ultimately becomes sufficient to turn CR11 and CR12 ON, discharging C17 as well. Until these diodes are turned on, the peak voltage on C17 is held constant. This permits the meter to mechanically rise to the full peak value and to display the peaks accurately.

4) De-Esser Control Circuitry

The VCA output (which includes the effect of IC13B, the de-esser gain-control element) is applied to the de-esser control module. This contains circuitry which detects the presence of sibilance and which outputs a current when sibilance levels exceed a level set by R55, the de-esser SENSITIVITY control.

The output current of the de-esser control module is applied to CR15 and CR17, which charge C18 and C19 to approximately equal positive voltages. The release time of the circuit is determined by R49 which discharges C19. When C19 has been discharged sufficiently to overcome the turn-on voltage of CR16, C18 will also discharge. Since the voltage on C18 determines the amount of de-esser gain reduction, this recovery delay function provided by CR17 substantially aids in smoothing the de-esser control voltage and reduces dynamic distortion.

IC9A is a non-inverting voltage-to-current converter. When the de-esser control voltage (across C19) is at ground, 15 volts appears across R47 because feedback holds IC9A's (+) and (-) inputs at the same voltage. This causes current to flow in R47, which flows into the emitter of IC8A. Essentially the same amount of current flows out of IC8A's collector to the control-current port of IC13B, thus determining the quiescent gain of IC13B.

When the de-esser gain control voltage becomes more positive, the voltage across R47 is decreased, thus reducing the control current into IC13B and reducing the gain of the VCA.

When the de-esser control voltage becomes more positive than 0.1 volt (corresponding to 0.06dB gain reduction), it turns on IC20B and lights the NORM de-esser LED. When the control voltage becomes more positive than 10 volts (corresponding to 9.5dB gain reduction), it turns on IC20A and lights the HEAVY de-esser LED.

5) VCA LEVEL Meter

The peak-detecting VCA LEVEL meter monitors the output of the VCA at IC9B. This meter is driven by a peak detector with peak-holding capability, and is capable of reading the peak level of a 10 microsecond pulse with an accuracy of 0.5dB

(typical) when compared to its reading on a steady-state tone. It thus provides a true peak-reading capability rather than a quasi-peak capability like an EBU-standard PPM.

The output of IC9B is rectified by an inverting half-wave precision rectifier IC15B and associated components. Twice the output of the rectifier is summed (through R34) with its input to create a full-wave rectified signal at the (+) input of IC19A.

IC19A and IC19B operate as a peak detector with peak-holding capabilities in a manner very similar to the G/R meter driver. The reader is referred to the **Gain Reduction Meter** section of **(3) (Compressor/Limiter Control Circuitry)**, above, for details.

To achieve the very fast response desired, the peak-holding capacitors C12 and C13 were made relatively small. To achieve a sufficiently slow recovery time with a practical value resistor (R38=22meg), R38 is bootstrapped to the output of IC19B through R36. R37 introduces enough DC offset to produce approximately 0.5 volts across R38 at all times. This multiplies the effective value of R38 by about 30x, slowing down the recovery time as desired.

6) Power Supply

Unregulated voltage is supplied by two pairs of full wave diode rectifiers CR31, CR32 and CR33, CR34 operating into a pair of energy storage capacitors C28, C29. The power transformer T1 is switchable for either 115 volt or 230 volt operation; the two sections of the primary are paralleled for 115 volt operation and connected in series for 230 volt operation.

The nominal unregulated voltage is ± 22 volts DC at rated line voltage. This will vary widely with line voltage variations. Regulator dropout will occur if the unregulated voltage falls below about ± 17.8 volts.

Regulated voltages are supplied by a pair of overrated 500mA "three terminal" IC regulators IC5, IC6. Because they are operated so conservatively, they can be expected to be extremely reliable. Therefore, before replacing the regulators, check to see whether other abnormalities in the circuitry (such as a shorted IC) have caused excessive current demand which is causing the regulator IC's to go either into current limiting or into thermal shutdown, their two built-in protective modes. If it becomes necessary to replace a regulator, be sure to replace its heat dissipator securely.

The regulators IC5 and IC6 are frequency-compensated by C30, C31 at their outputs to prevent high frequency oscillations. If C30 or C31 are ever replaced, be sure to use low-inductance aluminum electrolytics. Tantalums can fail because the current-delivering capacity of the power supply can cause a runaway condition if the dielectric is punctured momentarily; high-inductance aluminums can fail to prevent the regulators from oscillating. It is therefore necessary to check for oscillation on the power bus with an oscilloscope if C30 or C31 is replaced. In addition, small 0.05 μ F/25V ceramic capacitors bypass the power busses to ground locally throughout the board to prevent signal-carrying IC's from oscillating due to excessive power-lead inductance.

Appendix A:

Interconnections and Grounding

Small systems usually come together easily because cable runs are usually short and the interconnections between various pieces of equipment are not terribly complex. Therefore, do not be intimidated by the seeming complexity of the discussion on interconnections and grounding below. This is more information than most people will ever need to successfully install a small system; we have included it in case things don't work right and you need to find out why.

DRIVING THE 424A FROM HIGH IMPEDANCE/ HIGH LEVEL SOURCES

Both "+" and "-" sides of the inputs are bypassed to chassis ground for RF through 1000pF capacitors. To assure common mode rejection, and to assure that these capacitors do not affect the frequency response of the system, the output impedance of the equipment driving the 424A should be 600 ohms or less. Most professional and semi-professional sound equipment will satisfy this requirement.

The 424A can be driven by unbalanced sources of up to 10,000 ohms (such as the outputs of some vacuum tube preamps) by removing the 1000pF capacitors from the "+" inputs, and driving these inputs from the hot side of the driving equipment's outputs. (See the section below on **Grounding** for an explanation of balanced and unbalanced connections.)

If the 1000pF capacitors are left in place and the source impedance is 10K, the capacitors will cause a high frequency rolloff which is 3dB down at 16kHz, and which rolls off at 6dB/octave thereafter.

The absolute clipping level of the 424A input is +20dBm. If levels greater than +20dBm are expected, an external loss pad must be used before the input. The Audio Cyclopedia, Section 5, contains instructions for making such pads. (Tremaine, H.M.: The Audio Cyclopedia, Second Edition, Indianapolis, Howard W. Sams & Co., Inc., 1969).

GROUNDING

Grounding serves two purposes: it joins the common references of various pieces of electronic equipment, and it shields the electronics from various electric fields (RFI and hum).

(Interference caused by magnetic fields is not decreased by conventional shielding, and special magnetic shielding materials must be used for this type of problem. In audio, such shielding is ordinarily used with low-level magnetic transducers like tape heads, magnetic phono cartridges, and dynamic microphones, and with low-level transformers. Line-level processors such as the 424A are not normally sensitive to this sort of interference.)

There are two types of ground: circuit and chassis. Circuit ground serves as a common reference for the electronics. Chassis ground permits use of the chassis as a shield in the same way that the shield on shielded cable protects the inner conductors. Whether the circuit and chassis grounds are identical, are separate, or are separable depends on the type of equipment and the interconnecting scheme.

In professional systems correct grounding is important. The general principles are these:

- 1) In an audio system, the chassis of each piece of equipment should be connected to a good common ground point (ideally a cold water pipe or a rod driven into the earth) by one and only one wire.
- 2) Meanwhile, there must be one and only one circuit ground path between each piece of equipment.

It is when these two requirements become confused, omitted, or redundant that problems develop. If there is a connection missing, hum and noise will result. If more than one ground path exists, then a "ground loop" may develop.

A ground loop can be viewed as a single turn of a giant transformer. Because 60Hz AC magnetic fields exist in every area served by mains power, a ground loop will have a hum current induced in it by stray AC magnetic fields. Because a ground wire has appreciable impedance, this induced current will cause a hum voltage to appear between different parts of the ground system. If great care is not taken, this hum voltage can intrude on the audio signal.

How grounding is accomplished depends on whether the equipment to be interconnected is balanced or unbalanced.

An unbalanced connection uses two terminals: "hot" and ground. Wires used in such connections are typically single-conductor shielded. (RCA plugs and two-conductor phone plugs are often used to terminate such cables.) If because of stray fields or ground loops, a hum voltage appears between "hot" and ground, then this hum will be mixed into the desired signal since the unbalanced connection cannot distinguish between the desired signal and hum.

In the case of balanced connections, audio is applied to the "+" and "-" terminals; the input responds to the difference between the voltages at the two terminals. A third terminal is connected to chassis ground and is available for the connection of the shield of the two-conductor shielded wire that would be used (Belden 8451, for example). If a hum voltage is developed between the shield and both audio wires, then the balanced input would reject this "common mode" voltage, since the input responds only to the difference in voltage between the audio wires. This ability to reject hum and noise is the primary advantage of a balanced configuration.

Referring back to the **ELECTRICAL INSTALLATION** section, notice how these rules are applied in the table and diagram.

For involved systems such as arena-type sound reinforcement, professional recording studios, or large broadcasting facilities, a formal and systematic "transmission ground system" should be worked out for the entire system. See Section 24 of The Audio Cyclopedia for details (mentioned earlier).

(Interesting digression: The "balanced" technique was first perfected by the telephone company, which has to run miles of unshielded cables close to each other and also to high voltage AC lines without pickup of excessive hum or crosstalk from other circuits. Originally, telephone circuits were unbalanced on single wires, with the earth providing the ground return. As soon as electric lighting became popular and power lines were placed on telephone poles, the power lines interfered with the telephone service so badly as to render conversation impossible. The telephone company embarked on a research program which led to both the balanced line technique, and to the choice of the familiar 600 ohm impedance as the optimum compromise between rejection of electrical and magnetic interference. Today, the telephone company's specification for maintenance of line balance is extremely tight, as proper common mode rejection is vital to the success of the entire system.)

Appendix B: Specifications

Input

Impedance: greater than 10 k ohms active balanced

Level: -15dBm produces 10dB gain reduction with ATTACK TIME control centered, INPUT ATTEN control fully CW, and RATIO control at infinity-to-one.

Absolute Overload Level: +21dBm

Output

Impedance: approximately 100 ohms, electronically balanced to ground

Level: +4dBm nominal; absolute peak overload occurs at +26dBm

Frequency Response

±0.25dB 20-20,000 Hz below limiting and de-esser thresholds

Compressor/Limiter Section

Attack Time: manually adjustable in approximate range of 500us to 200ms; automatically scaled by program content.

Release Time: adjustable in approximate range of 0.8dB/sec to 20dB/sec; automatically scaled by program content. Switch-selectable LINEAR and EXPONENTIAL release shapes.

Compression Ratio: adjustable from 2:1 to infinity-to-one at threshold. Lower ratios automatically increase beyond threshold.

Range Of Gain Reduction: 25dB

Tracking Of Multiple Channels: ±0.5dB

Total Harmonic Distortion (ATTACK and RELEASE TIME controls centered; infinite RATIO; 15dB gain reduction): less than 0.05% @1kHz. Typically 0.25% @20Hz; 0.02% @100Hz; 0.02% @1kHz; 0.035% @10kHz.

SMPTÉ IM Distortion (controls set as above; 60/7000Hz 4:1; 15dB gain reduction): typically 0.03%

De-Esser Section

Attack Time: approximately 1 ms

Release Time: approximately 30 ms

Harmonic Distortion: less than 0.05% THD introduced by de-essing action @10kHz

Available Gain Reduction: greater than 25dB

System Noise

RMS noise in 20-20kHz bandwidth better than 85dB below output clipping threshold for any degree of gain reduction; 90dB typical.

Crosstalk (424A Only)

Better than -70dB @20kHz. Unmeasurable below 10kHz.

Operating Controls

Compressor/Limiter

INPUT ATTENUATOR

COMPRESSION RATIO

ATTACK TIME

RELEASE TIME

RELEASE SHAPE

GATE THRESHOLD

OUTPUT TRIM

IDLE GAIN

COMPRESSOR/LIMITER OP/DEFEAT

OUTPUT ATTEN (rear panel)

De-Esser
THRESHOLD
DE-ESSER OP/DEFEAT

General
STEREO COUPLING (424A only)
POWER ON/OFF

Indicators

Compressor/Limiter
GAIN REDUCTION METER
GATED LED
VCA LEVEL METER

De-Esser
NORMAL De-essing LED
HEAVY De-essing LED

Power Requirement

115/230 VAC \pm 10%; 50-60Hz. U-ground power cord attached.

Dimensions

19" (48.3cm) wide x 3.5" (8.9cm/2 units) high x 10" (25.4cm) deep

Operating Temperature

0-45 degrees C

Warranty

One year, parts and labor. Subject to limitations set forth in our Standard Warranty Agreement.

Parts List

Parts are listed by part class by assembly in Reference Designator order except for certain widely used common parts such as:

Fixed Resistors
3/8" Square Trimmer Resistors
Signal Diodes

which are described generally under the appropriate heading and which must be examined to determine the exact value.

OBTAINING SPARE PARTS

Because special or subtle characteristics of certain components are exploited in order to produce an elegant design at a reasonable cost, it is unwise to make substitutions for listed parts. It is also unwise to ignore notations in the Parts List indicating "Selected" or "Realignment Required" when replacing components. In such cases, the factory should be consulted if optimum performance is to be maintained.

Orban normally maintains an inventory of tested, exact replacement spare parts to supply any present or normal future demand quickly at nominal cost.

When ordering parts from the factory, we will need all of the following information:

- The Orban Part Number, if ascertainable
- The Reference Designator for a defective component
- A brief description of the part
- From the Serial Label on the rear:
 - The exact Model Number
 - The Serial Number
 - The "M" number, if any

Orban can supply standardized Spare Parts Kits for this product during its production life. Consult your dealer or the factory for the consist of such kits and their prices.

Parts for this unit have been chosen from the catalogs of well-known manufacturers for ease in future maintenance. The U.S. headquarter addresses are listed at the end of the Parts List. Most manufacturers have extensive distribution facilities throughout the world and may often be contacted through local offices.

REF DES	DESCRIPTION	ORBAN P/N	VEN (1)	VENDOR P/N	ALTERNATE VENDORS (1)	QUAN/ SYS.	NOTES
<u>MODULES</u>							
A1	Module, Timing	30590-000				1	
A2	Module, DSC	30585-000				1	
<u>CAPACITORS</u>							
<u>Chassis Assembly</u>							
C1	Ceramic, 1000V, .001uF	21112-210	CRL	DD-102		4	
C2	Same as C1						
<u>PCB Main Assembly</u>							
C3	Mica, 500V, 22pF, +.5pF	21020-022	CD	CD15ED220D03		2	
C4	Aluminum, Radial, 50V, 47uF	21208-647	SPR	502D476G050C01C		2	
C5	Same as C4						
C6	Polyester, Radial, 10%, 100V, 1.0uF	21441-510	PLE	160-60H105J100		1	
C7	Polyester, Radial, 10%, 100V, .1uF	21441-410	PLE	160-60C104J100		3	
C8	Mica, 5%, 500V, 150pF	21020-115	CD	CD15FD151J03		1	
C9	Mica, +.5pF, 500V, 5pF	21017-005	CD	CD15CD050D03		1	
C10	Mica, 5%, 500V, 47pF	21020-047	CD	CD15ED470J03		1	
C11	Same as C3						
C12	Polyester, Radial, 10%, 100V, .01uF	21401-310	SPR	225P10391WD3		2	
C13	Same as C12						
<u>Chassis Assembly</u>							
C14	Same as C1						
C15	Same as C1						
<u>PCB Main Assembly</u>							
C16	Tantalum, 10%, 35V, 4.7uF	21307-547	SPR	196D475X9035HA1		1	
C17	Tantalum, 10%, 35V, .22uF	21307-422	SPR	196D224X9035HA1		1	
C18	Same as C7						
C19	Same as C7						
C20	Not Used						
C21	Mica, +.5pF, 500V, 10pF	21017-010	CD	CD15CD100D03		2	
C22	Mica, 5%, 500V, 100pF	21020-110	CD	CD15FD101J03		2	
C23	Polyester, Radial, 10%, 100V, .047uF	21401-347	SPR	225P47391WD3		1	
C24	Tantalum, 10%, 35V, 1.0uF	21307-510	SPR	196D105X9035HA1		1	
C25	Same as C21						

FOOTNOTES:

- (1) See last page for abbreviations
- (2) No Alternate Vendors known at publication
- (3) Actual part is specially selected from part listed, consult Factory
- (4) Realignment may be required if replaced, see Circuit Description and/or Alignment Instructions

SPECIFICATIONS AND SOURCES FOR
REPLACEMENT PARTS
GATED COMP/LIM MODEL 422A/424A
Rev. 01 6/82
MODULES/CAPACITORS

REF DES	DESCRIPTION	ORBAN P/N	VEN (1)	VENDOR P/N	ALTERNATE VENDORS (1)	QUAN/ SYS.	NOTES
CAPACITORS, cont'd							
C26	Same as C22						
C27	Same as C23						
C28	Aluminum, Axial, 40V, 1000uF	21224-810	SIE	82000		2	
C29	Same as C28						
C30	Aluminum, Radial, 25V, 22uF	21206-622	SPR	502D226G025BB1C		2	
C31	Same as C30						
C32	Ceramic, 20%, 25V, .05uF	21106-350	CRL	UK25-503		7	
C33	Same as C32						
C34	Same as C32						
C35	Same as C32						
C36	Same as C32						
C37	Same as C32						
C38	Same as C32						
DIODES							
ALL DIODES NOT OTHERWISE LISTED BY REFERENCE DESIGNATOR ARE:							
	Diode, Signal	22101-000	FSC	1N4148	Many	26	
NOTE: This is a silicon small-signal diode, ultra fast recovery, high conductance. It may be replaced with 1N914 or, in Europe, with BAY 61. BV: 75V min. @ I _r = 5V I _r : 25nA max. @ V _r = 20V V _f : 1.0V max. @ I _f = 100mA t _{rr} : 4ns max.							
CR4	LED, Green	25104-000	FSC	FLV-350		1	
CR19	LED, Yellow	25105-000	FSC	FLV-450		1	
CR21	LED, Red	25103-000	FSC	FLV-150		1	
CR31	Diode, Rectifier, 1A	22201-400	MOT	IN4004		4	
CR32	Same as CR31						
CR33	Same as CR31						
CR34	Same as CR31						
INTEGRATED CIRCUITS							
IC1	Linear, Dual Opamp, LF412	24209-202	NAT	LF-412CN		7	
IC2	Linear, Single Opamp, 5534	24014-202	SIG	NE5534		2	
IC3	Multiple Discrete, CA3096	24406-302	RCA	CA3096AE		3	
IC4	Linear, Dual Opamp, 5532	24207-202	SIG	NE5532		1	
IC5	D.C. Regulator, 15V Positive	24304-901	FSC	uA78M15UC		1	

FOOTNOTES: (1) See last page for abbreviations (2) No Alternate Vendors known at publication (3) Actual part is specially selected from part listed, consult Factory (4) Realignment may be required if replaced, see Circuit Description and/or Alignment Instructions	SPECIFICATIONS AND SOURCES FOR REPLACEMENT PARTS GATED COMP/LIM MODEL 422A/424A Rev. 01 6/82 CAPACITORS/DIODES/INTEGRATED CIRCUITS
--	--

REF DES	DESCRIPTION	ORBAN P/N	VEN (1)	VENDOR P/N	ALTERNATE VENDORS (1)	QUAN/ SYS.	NOTES
<u>INTEGRATED CIRCUITS, cont'd</u>							
IC6	D.C. Regulator, 15V Negative	24303-901	FSC	uA79M15AUC		1	
IC7	Same as IC3						
IC8	Same as IC3						
IC9	Linear, Dual Opamp, TL072	24206-202	T1	TL072C		1	
IC10	Same as IC1						
IC11	Same as IC1						
IC12	Same as IC1						
IC13	Linear, Dual Gain Block	24208-303	ORB			1	
IC14	Same as IC2						
IC15	Same as IC1						
IC16	Linear, Dual Opamp, 4558	24202-202	RAY	RC4558	Many	2	
IC17	Same as IC16						
IC18	Same as IC1						
IC19	Same as IC1						
IC20	Linear, Dual Opamp, 1458	24203-202	MOT	1458C		1	
<u>INDUCTORS</u>							
<u>Chassis Assembly</u>							
L1	RF Choke, 1mH	29502-000	MIL	4662		2	
L2	Same as L1						
<u>TRANSISTORS</u>							
Q1	Signal, PNP, 2N4125	23001-101	MOT	2N4125		1	
Q2	Signal, NPN, 2N4123	23201-101	MOT	2N4123		2	
Q3	Same as Q2						
Q4	J-FET/P, J174	23407-101	SIL	J174		1	
Q5	J-FET/N, J113	23406-101	SIL	J113		1	
Q6	Signal, NPN, 2N4400	23202-101	FSC	2N4400		1	

FOOTNOTES:

- (1) See last page for abbreviations
- (2) No Alternate Vendors known at publication
- (3) Actual part is specially selected from part listed, consult Factory
- (4) Realignment may be required if replaced, see Circuit Description and/or Alignment Instructions

SPECIFICATIONS AND SOURCES FOR
REPLACEMENT PARTS
GATED COMP/LIM MODEL 422A/424A
Rev. 01 6/82
INTEGRATED CIRCUITS/INDUCTORS/TRANSISTORS

REF DES	DESCRIPTION	ORBAN P/N	VEN (1)	VENDOR P/N	ALTERNATE VENDORS (1)	QUAN/ SYS.	NOTES
------------	-------------	-----------	------------	------------	--------------------------	---------------	-------

RESISTORS

ALL COMMON RESISTORS NOT LISTED ARE GENERALLY SPECIFIED THUS:

Replace resistors only with the same style and with the exact value as marked on the resistor body, lest performance or stability be compromised. If the resistor is damaged, consult the factory or refer to the Schematic to obtain the value.

Metal Film Resistors

Body: conformally-coated
 I.D.: five color bands or printed value
 Orban P/N: 2004X-XXX
 Power Rating: 1/8 Watt @ 70°C
 Tolerance: 1%
 Temperature Coefficient: 100 PPM/°C
 U.S. Military Spec.: MIL-R-10509, Style RM55D
 Manufacturers: R-0hm (CRB- $\frac{1}{2}$ FX), TRW/IRC, Beyschlag, Dale, Corning, Matsushita

Carbon Composition Resistors

Body: molded phenolic
 I.D.: four color bands
 Orban P/N: 2001X-XXX (20011 20014)
 Power Rating: (70°C) $\frac{1}{4}$ Watt (Body 0.090" x 0.250")
 $\frac{1}{2}$ Watt (Body 0.140" x 0.375")
 Tolerance: 5%
 U.S. Military Spec.: MIL-R-11, Style RC-07 (\pm W) or RC-20 ($\frac{1}{2}$ W)
 Manufacturers: Allen-Bradley, TRW/IRC, Stackpole, Matsushita

Carbon Film Resistors

Body: conformally-coated
 I.D.: four color bands
 Orban P/N: 20001-XXX
 Power Rating: $\frac{1}{4}$ Watt @ 70°C
 Tolerance: 5%
 Manufacturers: R-0hm (R-25), Piher, Beyschlag, Dale, Phillips, Matsushita

Cermet Trimmer Resistors

Body: 3/8" square (9mm)
 I.D.: printed marking on side
 Orban P/N: 20510-XXX
 Power Rating: $\frac{1}{4}$ Watt @ 70°C
 Tolerance: 10%
 Temperature Coefficient: 100 PPM/°C
 Manufacturers: Beckman (72PR-series), Spectrol, Bourns, Matsushita

PCB Main Assembly

R5 Pot, Single (5020), 5K CTS 270-SERIES 1
 R14 Pot, Single (5050), 50K CTS 270-SERIES 2

Chassis Assembly

R23 Pot, Single (5020), \pm 10%, 50K 20721-000 1

PCB Main Assembly

R55 Pot, Single, 10K, CCW Log CTS 270-Series 1
 R64 Pot, Single, 10K, Linear CTS 270-Series 1
 R68 Pot, Single, 100K, CW Log CTS 270-Series 1
 R72 Same as R14
 R79 Pot, Dual, 50K/50K, CCW Log CTS 270-Series 1
 R92 Pot, Single, 10K, Linear CTS 270-Series 1

FOOTNOTES:

- (1) See last page for abbreviations
- (2) No Alternate Vendors known at publication
- (3) Actual part is specially selected from part listed, consult Factory
- (4) Realignment may be required if replaced, see Circuit Description and/or Alignment Instructions

SPECIFICATIONS AND SOURCES FOR

REPLACEMENT PARTS
 GATED COMP/LIM MODEL 422A/424A
 Rev. 01 6/82
 RESISTORS

REF DES	DESCRIPTION	ORBAN P/N	VEN (1)	VENDOR P/N	ALTERNATE VENDORS (1)	QUAN/ SYS.	NOTES
------------	-------------	-----------	------------	------------	--------------------------	---------------	-------

SWITCHES

PCB Main Assembly

S1	Push-Push, DPDT, "Release Shape"	26112-000	SCH	F-Series		1	
S2	Push-Push, DPDT, "Comp/Lim"	26114-000	SCH	F-Series		1	
S3	Push-Push, DPDT, "De-Essing"	26114-000	SCH	F-Series		1	

Chassis Assembly

S4	Push-Push, DPDT, "Stereo Couple"	26112-000	SCH	F-Series		1	
S5	Push-Push, DPDT, "Power"	26113-000	SCH	F-Series		1	
S6	Line Voltage Select	26140-000	SWC	EPS1-SL1		1	

MISCELLANEOUS

Chassis Assembly

F1	Fuse, Slo-Blo, 1/8A, 3AG	28004-113	LFE	313000		1	
M1	Meter, "IG/R", 1mADC F.S.	28010-002	EMI	13-F		1	
M2	Meter, "OUTPUT LEVEL", 1mADC F.S.	28010-001	EMI	13-F		1	
T1	Power Transformer, 38VCT	55001-000	ORB			1	
	Line Cord	28101-000	BEL	17237		1	
	Lamp, Pilot	25301-000	SYL	1847		2	

P/L REVISIONS

06029-VER-01 Final
30580-VER-02 Main PCB

FOOTNOTES:

- (1) See last page for abbreviations
- (2) No Alternate Vendors known at publication
- (3) Actual part is specially selected from part listed, consult Factory
- (4) Realignment may be required if replaced, see Circuit Description and/or Alignment Instructions

SPECIFICATIONS AND SOURCES FOR
REPLACEMENT PARTS
GATED COMP/LIM MODEL 422A/424A
Rev. 01 6/82
SWITCHES/MISCELLANEOUS

Vendor Codes

AB	Allen-Bradley Co. 1201 South Second St. Milwaukee, WI 53204	COR	Corcom, Inc. 1600 Winchester Road Libertyville, IL 60048	MIL	J. W. Miller Division Bell Industries 19070 Reyes Avenue P. O. Box 5825 Compton, CA 90221	RCA	RCA Solid State Division Route 202 Somerville, NJ 08876
AD	Analog Devices, Inc. Route 1, Industrial Park P.O. Box 280 Norwood, MA 02062	CRL	Centralab Electronics Div. Globe-Union Inc. 5757 North Green Bay Ave. Milwaukee, WI 53201	MON	Monsanto Commercial Products Co. Electronics Division 3400 Hillview Ave. Palo Alto, CA 94304	SCH	ITT Schadow, Inc. 8081 Wallace Road Eden Prairie, MN 55343
AM	Amphenol North America A Division of Bunker-Ramo 2122 York Road Oak Brook, IL 60521	CTS	CTS Corporation 905 N. West Blvd. Elkhart, IN 46514	MOT	Motorola, Inc. P. O. Box 20912 Phoenix, AZ 85036	SIE	Siemens Components Division 186 Wood Avenue, South Iselin, NJ 08830
BEK	Beckman Instruments, Inc. Helipot Division 2500 Harbor Blvd. Fullerton, CA 92634	ECL	Electrocube 1710 South Del Mar Avenue San Gabriel, CA 91776	NAT	National Semiconductor Corp. 2900 Semiconductor Drive Santa Clara, CA 95051	SIG	Signetics Corporation A Subsidiary of U.S. Philips Corp. P. O. Box 9052 Sunnyvale, CA 94086
BEL	Belden Corporation Electronic Division Richmond, IN 47374	ERE	Erie Technological Products, Inc. 644 West Twelfth Street Erie, PA 16512	NOB	Noble Teikoku Tsushin Kogyo Co. Ltd. 335, Kariyado, Nakahara-ku Kawasaki 211, JAPAN	SPR	Sprague Electric Company 125 Marshall Street North Adams, MA 01247
BRN	Burns, Inc. Triplot Products Division 1200 Columbia Ave. Riverside, CA 92507	EXR	Exar Integrated Systems, Inc. P. O. Box 62229 Sunnyvale, CA 94088	OHM	Ohmite Manufacturing Company A North American Philips Co. 3601 Howard Street Skokie, IL 60076	STK	Stackpole Components Company P. O. Box 14466 Raleigh, NC 27620
BUS	Bussmann Manufacturing Div. McGraw-Edison Company P. O. Box 14460 St. Louis, MO 63178	FSC	Fairchild Camera & Instr. Corp. 464 Ellis Street Mountain View, CA 94042	ORB	Orban Associates Inc. 645 Bryant Street San Francisco, CA 94107	SWC	Switchcraft 5527 N. Elson Avenue Chicago, IL 60630
CD	Cornell-Dubilier Electric Corp. Div. of Federal Pacific Electric 150 Avenue "L" Newark, NJ 07101	HP	Hewlett-Packard Corporation 1501 Page Mill Road Palo Alto, CA 94304	PAK	Paktron Div. of Illinois Tool Works Inc. 900 Follin Lane, S.E. Vienna, VA 22180	SYL	GTE Sylvania Inc. Connector Products Operation Box 29 Titusville, PA 16354
CH	Cutler-Hammer Products Division of Eaton Corporation 4201 N. 27th Street Milwaukee, WI 53216	INS	Intersil, Inc. 10710 N. Tantau Avenue Cupertino, CA 95014	PLE	Plessey, Inc. 5334 Stierling Ctr. Dr. Westlake Village, CA 91361	TI	Texas Instruments P. O. Box 225012 Dallas, TX 75265
CK	C & K Components Inc. 15 Riverdale Avenue Newton, MA 02158	LFE	Littelfuse A Subsidiary of Tracor 800 East Northwest Highway Des Plaines, IL 60016	RAY	Raytheon Semiconductor Division 350 Ellis Street Mountain View, CA 94042		
MAL	P. R. Mallory & Company, Inc. 3029 East Washington Street Indianapolis, IN 46206	MAL					

ASSEMBLY DRAWING AND SCHEMATIC

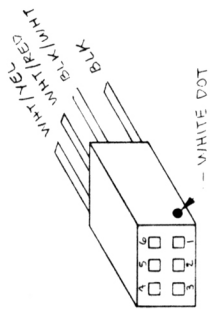

ILLUMINATION FOR FRONT PANEL METERS

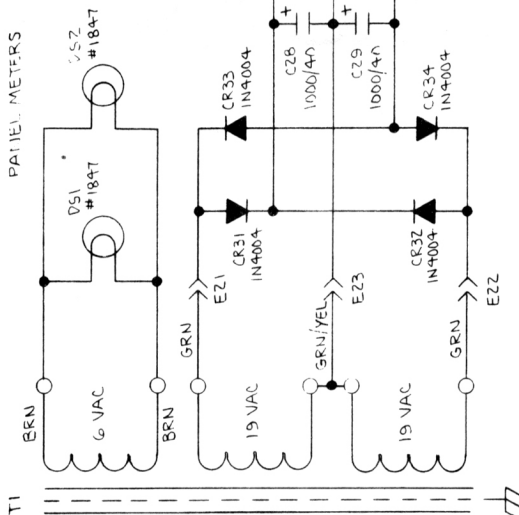

J1
(POWER TO SECOND PCB IN 429A)

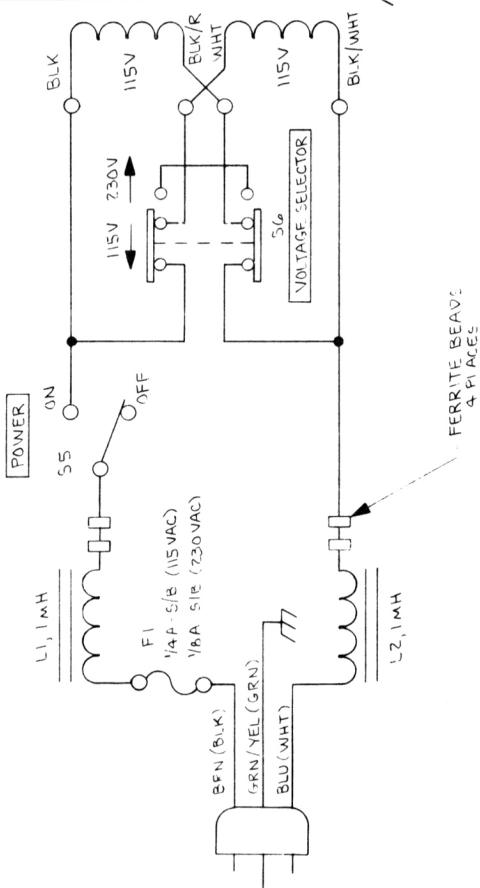
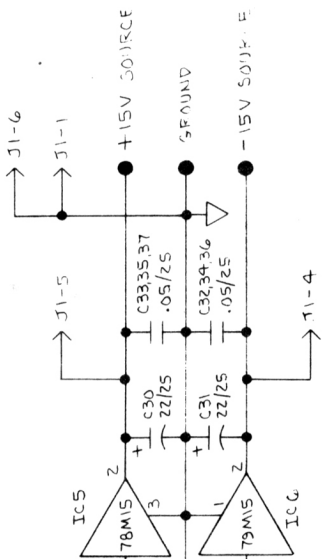

FERRITE BEAD
& PLACES

Orban	Orban Associates Inc.
	TITLE: SCHEMATIC POWER SUPPLY 60049-000-02

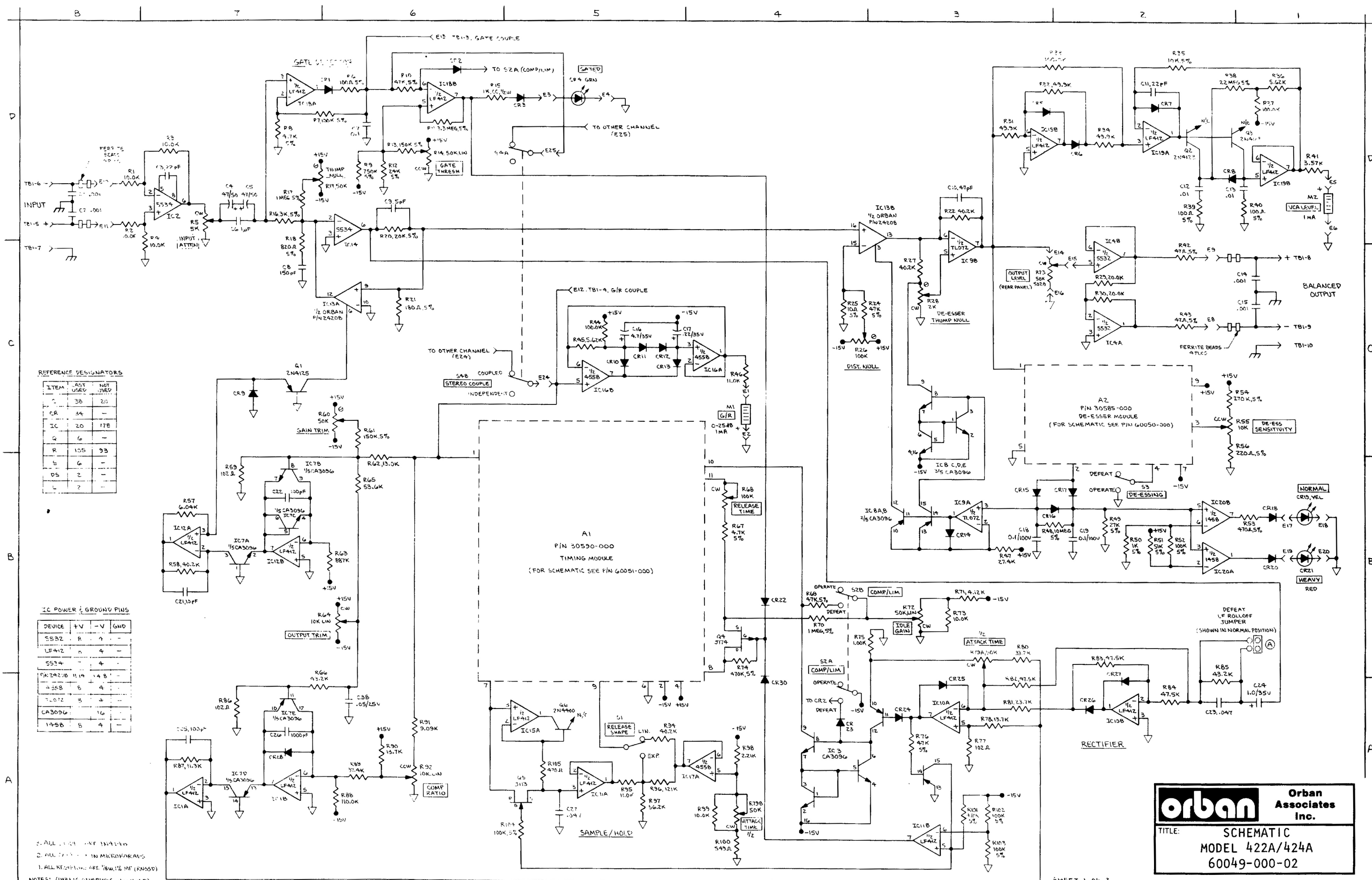

REFERENCE DESIGNATORS

ITEM	LAST USED	NOT USED
C	38	20
CR	34	-
IC	20	178
Q	6	-
R	105	93
S	6	-
DS	2	-
L	2	-

IC POWER & GROUND PINS

DEVICE	+V	-V	GND
5532	8	4	-
LF412	4	4	-
5534	-	4	-
PN2420B	11A	1A B	-
5558	8	4	-
TL072	8	4	-
CA3096	16	-	-
1458	8	4	-

1. ALL CAPS ARE IN MICROFARADS
 2. ALL CAPS ARE IN MICROFARADS
 3. ALL RESISTORS ARE 1% TOL UNLESS OTHERWISE SPECIFIED

Orban Associates Inc.
 TITLE: SCHEMATIC
 MODEL 422A/424A
 60049-000-02

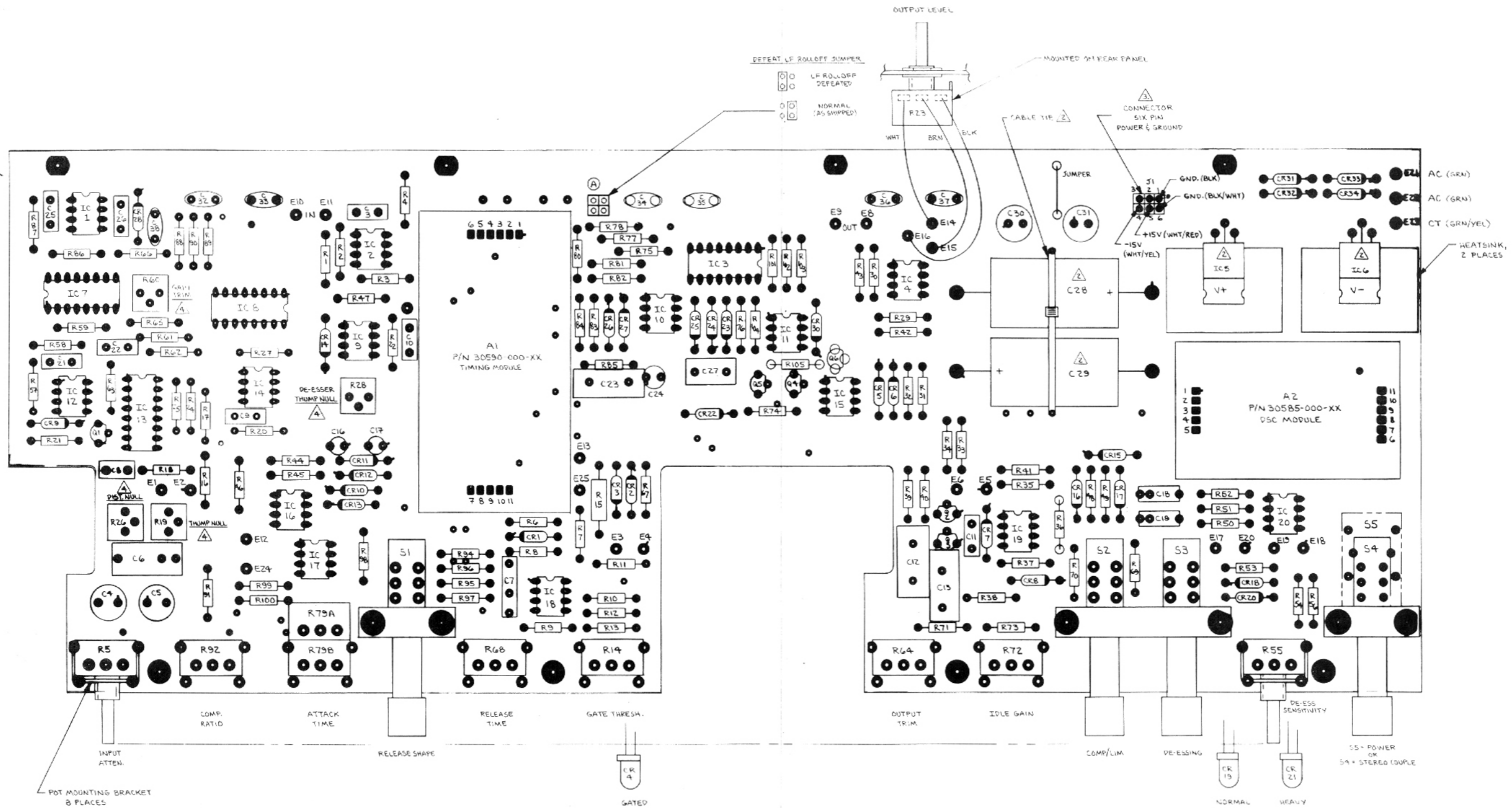

▲ FOR VER-002 INSTALL TRIMPOTS R19, 26, 28, 60 ON SOLDER SIDE.

▲ NOT INSTALLED ON VER-001

▲ NOT INSTALLED ON VER-002

1. VERSIONS: -001 (422A) = W/POWER SUPPLY (CR 31-34 IC 3&5, C26, 27; 424A)

-002 (424A) = W/O POWER SUPPLY (CR 31-34, IC 3&5, C26, 29 ONLY)

NOTES:

urban	Orban Associates Inc.
	TITLE: ASSEMBLY DRAWING MODEL 422A/424A 30580-000-02